



GGB HI-EX[®]

**METAL-POLYMER SUPERIOR PERFORMANCE
BEARING SOLUTIONS FOR LUBRICATED APPLICATIONS**

Who we are

GGB helps create a world of motion with minimal frictional loss through plain bearing and surface engineering technologies. With R&D, testing and production facilities in the United States, Germany, France, Brazil, Slovakia and China, GGB partners with customers worldwide on customized tribological design solutions that are efficient and environmentally sustainable. GGB's engineers bring their expertise and passion for tribology to a wide range of industries, including automotive, aerospace and industrial manufacturing. To learn more about tribology for surface engineering from GGB, visit www.ggbearings.com.

Our products are used in tens of thousands of critical applications every day on our planet. It is always our goal to provide superior, high-quality solutions for our customers' needs, no matter where those demands take our products. From space vehicles to golf carts and virtually everything in between; we offer the industry's most extensive range of high performance, maintenance-free bearing solutions for a multitude of applications:



Aerospace



Agriculture



Automotive



Construction



E-Mobility



Energy



Exoskeletons



Fluid Power



Industrial



Medical



Mining



Oil & Gas



Primary Metals



Railway



Recreation



Robotics & Automation

The GGB Advantage



MAINTENANCE-FREE

GGB bearings are self-lubricating, making them ideal for applications requiring long bearing life without continuous lubrication.



LOW FRICTION, HIGH WEAR RESISTANCE

Low coefficients of friction eliminate the need for lubrication, while providing smooth operation, reducing wear and extending service life.



NVH (NOISE, VIBRATION, HARSHNESS)

Plain bearings provide a smooth sliding motion between surfaces and their material properties and simple design reduce noise, vibration and harshness.



LOWER SYSTEM COST

A one-piece design offers space and weight reductions and thanks to the material compositions and self-lubricating properties, less maintenance is needed.



REDUCED CO₂ FOOTPRINT

GGB's flexible and local production platforms assure timely deliveries and reduced CO₂ footprint.



PARTNER SUPPORT

GGB offers tribological, application and design support, and partners with our customers to provide the most efficient solutions.



The Highest Standards in Fabrication

Our world-class manufacturing plants in the United States, Brazil, China, Germany, France and Slovakia are certified in quality and excellence according to ISO 9001, IATF 16949, ISO 14001 and ISO 45001. This allows us to access the industry's best practices while aligning our management system with global standards.

For a complete listing of our certifications, please visit our website:

www.ggbearings.com/en/certificates

Table of Contents

1 Introduction	5	6 Bearing Assembly	21
1.1 Characteristics and Advantages	5	6.1 Dimensions and Tolerances	21
2 Structure	6	6.2 Tolerances for minimum Clearance	21
2.1 Basic Forms	6	Grease Lubrication	21
3 Properties	7	Fluid Lubrication	23
3.1 Physical Properties	7	Allowance for thermal Expansion	23
3.2 Chemical Properties	7	6.3 Counterface Design	24
4 Lubrication and Friction	8	6.4 Installation	25
4.1 Dry Operation	8	Fitting of Bushes	25
4.2 Choice of Lubricant	8	Insertion Forces	25
Grease	8	Alignment	26
Oil	8	Sealing	26
Non lubricating Fluids	8	Axial Location	26
4.3 Friction	9	Fitting of Thrust Washers	27
4.4 Lubricated Environments	9	Slideways	27
Lubrication	9	7 Machining	28
4.5 Characteristics of Fluid Lubricated HI-EX® Bearings	10	7.1 Machining Practice	28
4.6 Design Guidance for Fluid Lubricated Applications	11	7.2 Boring	28
4.7 Wear Rate and Re-lubrication Intervals with Grease Lubrication	12	7.3 Reaming	29
Fretting Wear	12	7.4 Broaching	29
5 Design Factors	13	7.5 Vibrobroaching	30
5.1 Specific Load	13	7.6 Modification of Components	30
Specific Load Limit	13	7.7 Drilling Oil Holes	30
5.2 Sliding Speed	14	7.8 Cutting Strip Material	30
Continuous Rotation	14	8 Electroplating	31
Oscillating Movement	14	HI-EX® Components Mating Surfaces	31
5.3 PU Factor	15	9 Standard Products	32
5.4 Load	15	9.1 PM HI-EX® Cylindrical Bushes	32
Type of Load	15	9.2 MB HI-EX® Cylindrical Bushes	39
5.5 Temperature	16	9.3 HI-EX® Thrust Washers	43
5.6 Mating Surface	16	9.4 HI-EX® Sliding Plates	43
5.7 Bearing Size	17	10 Test Methods	44
5.8 Estimation of Bearing Service Life with Grease Lubrication	17	10.1 Measurement of Wrapped Bushes	44
Calculation Parameters	17	Test A of ISO 3547 Part 2	44
Estimated Re-greasing Interval	18	Test B (alternatively to Test A)	44
Oscillating Motion and Dynamic Loads	18	Test C of ISO 3547 Part 1	44
5.9 Worked Examples	19	Test D of ISO 3547 Part 2	44
		11 Data Sheet for Bearing Design	45
		Formula Symbols and Designations	46
		Product Information	47

1 Introduction

The purpose of this handbook is to provide comprehensive technical information on the characteristics of HI-EX® bearings. The information given permits designers to establish the correct size of bearing required and the expected life and performance. GGB Research and Development services are available to assist with unusual design problems.

Complete information on the range of HI-EX® standard stock products is given together with details of other HI-EX® products.

GGB is continually refining and extending its experimental and theoretical knowledge and, therefore, when using this brochure it is always worth-while to contact the Company should additional information be required.

As it is impossible to cover all conditions of operation which arise in practice, customers are advised to carry out prototype testing wherever possible.

1.1 CHARACTERISTICS AND ADVANTAGES

- HI-EX® provides maintenance free operation
- HI-EX® has a high PU capability
- HI-EX® exhibits low wear rate
- Seizure resistant
- Suitable for temperatures from -150 °C to +250 °C
- High static and dynamic load capacity
- HI-EX® polymer bearing lining has good chemical resistance
- No water absorption and therefore dimensionally stable
- Compact and light
- Suitable for rotating, oscillating, reciprocating and sliding movements
- HI-EX® bearings are prefinished and require no machining after assembly
- Suitable for use with low viscosity and low lubricant fluids.

2 Structure

HI-EX® is a composite bearing material developed specifically to operate with marginal lubrication and consists of three bonded layers: a steel backing strip and a sintered porous bronze matrix, impregnated and overlaid with a PEEK (polyetherether ketone) polymer bearing material, containing fillers including PTFE (polytetrafluorethylene).

The steel backing provides mechanical strength and the bronze interlayer provides a strong mechanical bond for the lining. This construction promotes dimensional stability and improves thermal conductivity, thus reducing the temperature at the bearing surface.

For grease lubricated applications HI-EX® is manufactured with a polymer overlay thickness above the bronze sinter layer of 0.30 mm nominal, and the bearing surface is provided with a uniform pattern of indentations. These serve as a reservoir for the grease and are designed to provide the optimum distribution of the lubricant over the bearing surface (e.g. PM2020HX).

For fluid lubricated applications where the bearing surface may be required to be machined subsequent to assembly, HI-EX® is manufactured with a polymer overlay thickness above the bronze sinter layer of 0.30 mm nominal, and the indent pattern omitted from the bearing surface (e.g. PM2020HXU).

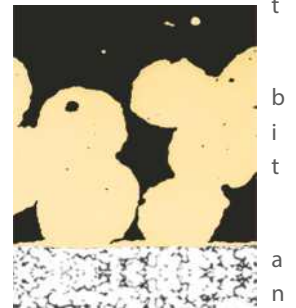

Fig. 1: HI-EX Microsection

2.1 BASIC FORMS

HI-EX®- STANDARD COMPONENTS (NOT AVAILABLE FROM STOCK)

These products are manufactured to International, National or GGB standard designs:

PM pre finished metric range, not machinable in situ, for use with standard journals finished to h6-h8 limits.
MB machinable metric range, with an allowance for machining in situ.

— Cylindrical Bushes



— Thrust Washers



Fig. 2: Standard Components

HI-EX®- NON STANDARD COMPONENTS

These products are manufactured to customers' requirements with or without GGB recommendations, and include for example:

— Modified Standard Components



— Half Bearings



— Flat Components



— Pressings



— Stampings



Fig. 3: Non Standard Components

3 Properties

3.1 PHYSICAL, MECHANICAL AND ELECTRICAL PROPERTIES

BEARING PROPERTIES		SYMBOL	UNIT	VALUE HI-EX®	COMMENTS
PHYSICAL PROPERTIES					
Thermal conductivity		λ	W/mK	52	
Coefficient of linear thermal expansion	parallel to surface	α_1	$10^{-6}/K$	11	
	normal to service	α_2		29	
Operating temperature		T_{max}	°C	+250	
		T_{min}		-150	
MECHANICAL PROPERTIES					
Compressive yield strength		σ_C	N/mm ²	380	measured on disc Ø 25 mm x 2.45 mm thick
Maximum load	static	$P_{sta,max}$	N/mm ²	140	
	dynamic	$P_{dyn,max}$		140	
ELECTRICAL PROPERTIES					
Volume resistivity of PEEK lining		P_D	Ωcm	>10 ⁹	

Table 1: Physical, mechanical and electrical properties of HI-EX

3.2 CHEMICAL PROPERTIES

The following table provides an indication of the chemical resistance of HI-EX® to various chemical media. It is recommended that the chemical resistance is confirmed by testing if possible.

CHEMICAL	%	°C	HI-EX®	CHEMICAL	°C	HI-EX®
STRONG ACIDS				SOLVENTS		
Hydrochloric Acid	5	20	-	Acetone	20	+
Nitric Acid	5	20	-	Carbon Tetrachloride	20	+
Sulfuric Acid	5	20	-	LUBRICANTS AND FUELS		
WEAK ACIDS				Paraffin	20	+
Acetic Acid	5	20	-	Gasolene	20	+
Formic Acid	5	20	-	Kerosene	20	+
BASES				Diesel Fuel	20	+
Ammonia	10	20	o	Mineral Oil	70	+
Sodium Hydroxide	5	20	o	HFA-ISO46 High Water Fluid	70	+
				HFC-Water-Glycol	70	+
				HFD-Phosphate Ester	70	+
				Water	20	o
				Sea Water	20	-

Table 2: Chemical Resistance of HI-EX

- + Satisfactory: Corrosion damage is unlikely to occur
- o Acceptable: Some corrosion damage may occur but this will not be sufficient to impair either the structural integrity or the tribological performance of the material
- Unsatisfactory: Corrosion damage will occur and is likely to affect either the structural integrity and/or the tribological performance of the material

4 Lubrication and Friction

4.1 DRY OPERATION

HI-EX® will operate satisfactorily without lubrication under light duty running conditions at PU factors below 0,01 N/mm² and sliding speeds U below 2.5 m/s.

The wear performance should be confirmed by testing if possible.

4.2 CHOICE OF LUBRICANT

HI-EX® will generally be lubricated, the choice of lubricant depending upon:

- PU and sliding speed
- the stability of the lubricant under the operating conditions

GREASE

The performance ratings of different types of grease are indicated in Table 3. Greases containing EP additives or significant additions of graphite or MoS₂ are not generally recommended for use with HI-EX®.

HI-EX® is able to withstand environmental temperatures beyond those generally suitable for grease lubrication and the performance is therefore likely to be limited by the lubricant and not by the bearing material. For environmental temperatures above 80 °C suitability of the grease should be established by test and a silicone oil base or high temperature grease is recommended. For applications above 150 °C PU values should be limited to below 1.0 N/mm² x m/s and re-lubrication intervals should not exceed 500 hours.

OIL

HI-EX® is recommended for use with oil lubrication. HI-EX® is compatible with mineral oils up to 150 °C and is resistant to the oxidation products which may occur with mineral oils at temperatures above 115 °C.

Degradation of oils is likely to occur following extended exposure to high temperatures and synthetic lubricants are recommended under these circumstances.

NON LUBRICATING FLUIDS

HI-EX® has been found to perform satisfactorily with low viscosity and non lubricating fluids such as polyethylene glycol and polyglycol lubricants, water-oil emulsion, shock-absorber oils, kerosene and water.

In general, the fluid will be acceptable if it does not chemically attack the PEEK lining or the porous bronze interlayer. Chemical resistance data are given in Table 2.

Where there is doubt about the suitability of a fluid, a simple test is to submerge a sample of HI-EX® material in the fluid for two to three weeks at 15-20 °C above the operating temperature. The following will usually indicate that the fluid is not suitable for use with HI-EX®.

- A significant change in the thickness of the HI-EX® material,
- A visible change in the bearing surface from polished to matt,
- A visible change in the microstructure of the bronze interlayer.

4 Lubrication and Friction

MANUFACTURER	GRADE	TYPE		RATING
		OIL	THICKENER	
BP	Energrease LS2	Mineral	Lithium Soap	+
	Energrease LT2	Mineral	Lithium Soap	+
	Energrease FGL	Mineral	Non Soap	o
	Energrease GSF	Synthetic	NA	o
Century	Lacerta ASD	Mineral	Lithium/Polymer	o
	Lacerta CL2X	Mineral	Calcium	-
Dow Corning	Molykote 55M	Silicone	Lithium Soap	o
	Molykote PG65	PAO	Lithium Soap	+
	Molykote PG75	Synthetic/Mineral	Lithium Soap	o
	Molykote PG602	Mineral	Lithium Soap	o
Elf	Rolexa.1	Mineral	Lithium Soap	+
	Rolexa.2	Mineral	Lithium Soap	o
	Epexelf.2	Mineral	Lithium/Calcium Soap	-
Esso	Andok C	Mineral	Sodium Soap	o
	Andok 260	Mineral	Sodium Soap	o
	Cazar K	Mineral	Calcium Soap	-
Mobil	Mobilplex 47	Mineral	Calcium Soap	-
	Mobiltemp 1	Mineral	Non Soap	o
Rocol	BG622	White Mineral	Calcium Soap	o
	Sapphire	Mineral	Lithium Complex	-
	White Food Grease	White Oil	Clay	-
Shell	Albida R2	Mineral	Lithium Complex	+
	Axinus S2	Mineral	Lithium	o
	Darina R2	Mineral	Inorganic Non Soap	+
	Stamina U2	Mineral	Polyurea	-
	Tivela A	Synthetic	NA	o
Total	Aerogrease	Synthetic	NA	+
	Multis EP2	NA	Lithium	+

Table 3: Performance of greases

+ Recommended o Satisfactory - Not recommended NA Data not available

4.3 FRICTION

The coefficient of friction of lubricated HI-EX® depends upon the actual operating conditions as indicated in section 4.4. Where frictional characteristics are critical to a design they should be established by prototype testing.

4.4 LUBRICATED ENVIRONMENTS

The following sections describe the basics of lubrication and provide guidance on the application of HI-EX® in such environments.

LUBRICATION

There are three modes of lubricated bearing operation which relate to the thickness of the developed lubricant film between the bearing and the mating surface.

These three modes of operation depend upon:

- Bearing dimensions
- Clearance
- Load and speed
- Lubricant viscosity and flow

4 Lubrication and Friction

HYDRODYNAMIC LUBRICATION

Characterised by:

- Complete separation of the shaft from the bearing by the lubricant film
- Very low friction and no wear of the bearing or shaft since there is no contact.
- Coefficients of friction of 0.001 to 0.01

Hydrodynamic conditions occur when:

$$(4.4.1) \quad P \leq \frac{U \cdot \eta}{7,5} \cdot \frac{B}{D_i} \quad [\text{N/mm}^2]$$

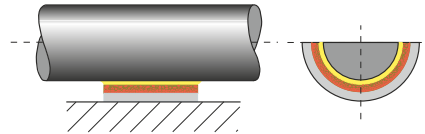

Figure 4: Hydrodynamic lubrication

MIXED FILM LUBRICATION

Characterised by:

- Combination of hydrodynamic and boundary lubrication.
- Part of the load is carried by localised areas of self pressurised lubricant and the remainder supported by boundary lubrication.
- Friction and wear depend upon the degree of hydrodynamic support developed.
- HI-EX® provides low friction and high wear resistance to support the boundary lubricated element of the load.

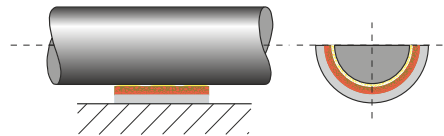

Figure 5: Mixed film lubrication

BOUNDARY LUBRICATION

Characterised by:

- Rubbing of the shaft against the bearing with virtually no lubricant separating the two surfaces.
- Bearing material selection is critical to performance.
- Shaft wear is likely due to contact between bearing and shaft.
- The excellent properties of HI-EX® material minimises wear under these conditions.
- The dynamic coefficient of friction with HI-EX® is typically 0.02 to 0.15 under boundary lubrication conditions.
- The static coefficient of friction with HI-EX® is typically 0.05 to 0.20 under boundary lubrication conditions.

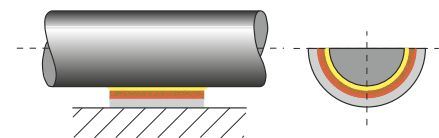

Figure 6: Hydrodynamic lubrication

4.5 CHARACTERISTICS OF FLUID LUBRICATED HI-EX® BEARINGS

HIGH LOAD CONDITIONS

In highly loaded applications operating under boundary or mixed film conditions HI-EX® shows excellent wear resistance.

START UP AND SHUT DOWN UNDER LOAD

With insufficient speed to generate a hydrodynamic film the bearing will operate under boundary or mixed film conditions.

- HI-EX® minimises wear

SPARSE LUBRICATION

Many applications require the bearing to operate with less than the ideal lubricant supply, typically with splash or mist lubrication only. The PEEK lining of HI-EX® has low thermal conductivity relative to conventional metallic bearings, and therefore depending upon the operating conditions may require a greater lubricant supply to remove the generated heat in the bearing.

– HI-EX® shows greater wear resistance than conventional metallic bearings.

4.6 DESIGN GUIDANCE FOR FLUID LUBRICATED APPLICATIONS

Fig. 7, Page 12 shows the three lubrication regimes discussed above plotted on a graph of sliding speed vs the ratio of specific load to lubricant viscosity.

NOTE:

Viscosity is a function of operating temperature. If the operating temperature of the fluid is unknown, a provisional temperature of 25 °C above ambient can be used.

AREA 1 OF FIGURE 7

The bearing will operate with boundary lubrication. The PU factor will be the major determinant of bearing life.

HI-EX® bearing performance can be estimated from the following:

Calculate effective PU factor from section 5.8.

If $ePU/\eta \leq 0.2$ then

$$(4.6.1) \quad L_H = \frac{2250}{\left(\frac{ePU}{\eta}\right)^{0.5}} \cdot a_Q \cdot a_T \cdot a_S \quad [h]$$

If $0.2 < ePU/\eta \leq 1.0$ then

$$(4.6.2) \quad L_H = \frac{1000}{\left(\frac{ePU}{\eta}\right)} \cdot a_Q \cdot a_T \cdot a_S \quad [h]$$

If $ePU/\eta > 1.0$ then

$$(4.6.3) \quad L_H = \frac{1000}{\left(\frac{ePU}{\eta}\right)^2} \cdot a_Q \cdot a_T \cdot a_S \quad [h]$$

ePU see (5.8.2), Page 18

AREA 2 OF FIGURE 7

The bearing will operate with mixed film lubrication.

PU factor is no longer a significant parameter in determining the bearing life.

HI-EX® bearing performance will depend upon the nature of the fluid and the actual service conditions.

AREA 3 OF FIGURE 7

The bearing will operate with hydrodynamic lubrication. Bearing wear will be determined only by the cleanliness of the lubricant and the frequency of start up and shut down.

AREA 4 OF FIGURE 7

These are the most demanding operating conditions.

- The bearing is operated under either high speed or high bearing load to viscosity ratio, or a combination of both.
- These conditions may cause
 - excessive operating temperature
 - and/or high wear rate.
- Bearing performance may be improved:
 - by use of unindented HI-EX® lining
 - by the addition of one or more grooves to the bearing
 - by shaft surface finish $R_a < 0.05 \mu\text{m}$.

4 Lubrication and Friction

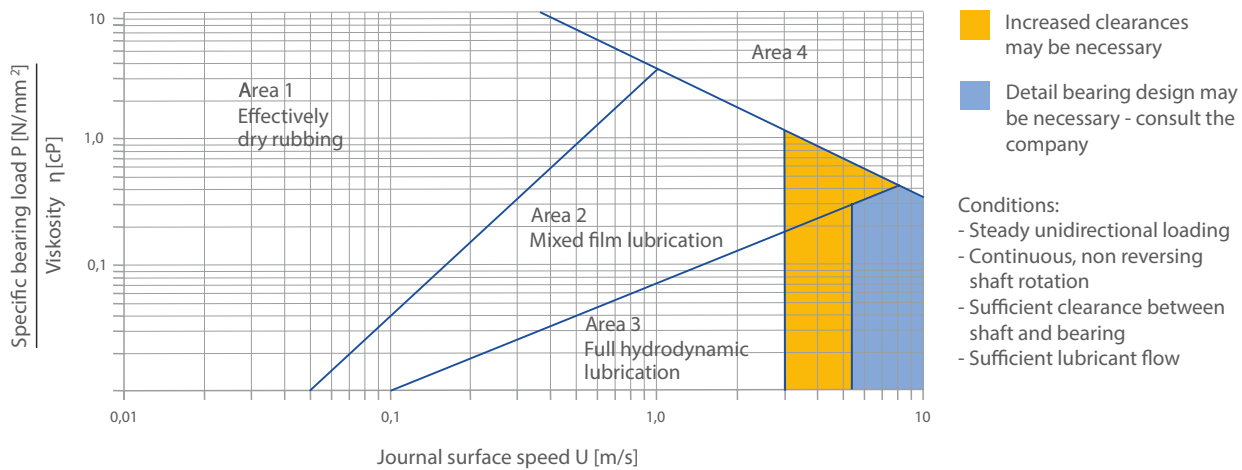

Fig. 7: Design guide for lubricated application

VISCOSITY cP															
TEMPERATURE [°C]	0	10	20	30	40	50	60	70	80	90	100	110	120	130	140
Lubricant															
ISO VG 32	310	146	77	44	27	18	13	9.3	7.0	5.5	4.4	3.6	3.0	2.5	2.2
ISO VG 46	570	247	121	67	40	25	17	12	9.0	6.9	5.4	4.4	3.6	3.0	2.6
ISO VG 68	940	395	190	102	59	37	24	17	12	9.3	7.2	5.8	4.7	3.9	3.3
ISO VG 100	2110	780	335	164	89	52	33	22	15	11.3	8.6	6.7	5.3	4.3	3.6
ISO VG 150	3600	1290	540	255	134	77	48	31	21	15	11	8.8	7.0	5.6	4.6
Diesel oil	4.6	4.0	3.4	3.0	2.6	2.3	2.0	1.7	1.4	1.1	0.95				
Petrol	0.6	0.56	0.52	0.48	0.44	0.40	0.36	0.33	0.31						
Kerosene	2.0	1.7	1.5	1.3	1.1	0.95	0.85	0.75	0.65	0.60	0.55				
Water	1.79	1.30	1.0	0.84	0.69	0.55	0.48	0.41	0.34	0.32	0.28				

Table 4: Viscosity data

4.7 WEAR RATE AND RE-LUBRICATION INTERVALS WITH GREASE LUBRICATION

At specific bearing loads below 100 N/mm² a grease lubricated HI-EX® bearing shows only small bedding-in wear of about 0.0025 mm. This is followed by little wear during the early part of the bearing life until the lubricant becomes exhausted and the wear rate increases. If the bearing is regreased before the rate of wear starts to increase rapidly the material will continue to function satisfactorily with little wear. Fig. 8 shows the typical wear pattern. Under specific loads above 100 N/mm² the initial bedding-in wear is greater, typically about 0.025 mm, followed by a decreasing wear rate until the bearing exhibits a similar wear/life relationship to that shown in Fig. 8.

The useful life of the bearing is limited by wear in the loaded area. If this wear exceeds 0.15 mm the grease capacity of the indents is reduced and more frequent regreasing of the bearing will be required.

FRETTING WEAR

Oscillating movements of less than the dimensions of the indent pattern may cause localised wear of the mating surface after prolonged usage. This will result in the indent pattern becoming transferred onto the mating surface in contact with the HI-EX® bearing and may also give rise to fretting corrosion damage. In this situation DS material should be considered as an alternative to HI-EX®.

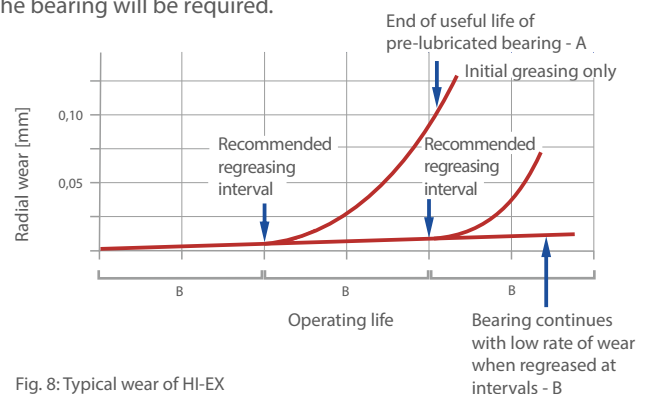

Fig. 8: Typical wear of HI-EX

5 Design Factors

The main parameters when determining the size or calculating the service life for a HI-EX® bearing are:

- Specific load limit P_{lim} [N/mm²]
- PU Factor [N/mm² x m/s]
- Mating surface roughness R_a [μm]
- Mating surface material
- Temperature T [°C]
- Other environmental factors eg. housing design, dirt, lubrication.

5.1 SPECIFIC LOAD

The specific load p is defined as the working load divided by the projected area of the bearing and is expressed in N/mm².

CYLINDRICAL BUSH

$$(5.1.1) \quad P = \frac{F}{D_i \cdot B} \quad [N/mm^2]$$

THRUST WASHER

$$(5.1.2) \quad P = \frac{4F}{\pi \cdot (D_o^2 - D_i^2)} \quad [N/mm^2]$$

SLIDE PLATE

$$(5.1.3) \quad P = \frac{F}{L \cdot W} \quad [N/mm^2]$$

SPECIFIC LOAD LIMIT

The maximum load which can be applied to a HI-EX® bearing can be expressed in terms of the specific load limit, which depends on the type of the loading and lubrication. It is highest under steady loads. Conditions of dynamic load or oscillating movement which produce fatigue stress in the bearing result in a reduction in the specific load limit. The values of specific load limit specified in table 5 assume good alignment between the bearing and mating surface.

The specific load limit for HI-EX® reduces for bearing operating temperatures in excess of 70 °C, falling to about half the values given in table 5 for temperatures above 150 °C.

Conditions of dynamic load or oscillating movement which produce fatigue stress in the bearing result in a reduction in the permissible specific load limit (Fig. 9, page 14).

LOAD	OPERATING CONDITION	LUBRICATION	P_{lim}
Steady	Intermittent or very slow (below 0,01 m/s) continuous rotation or oscillating motion	Grease or oil	140
Steady	Continuous rotation or oscillating motion	Grease or oil (boundary lubrication)	90
Steady or dynamic	Continuous rotation or oscillating motion	Oil (hydrodynamic lubrication)	60

Table 5: Specific load limit P_{lim} for HI-EX

5 Design Factors

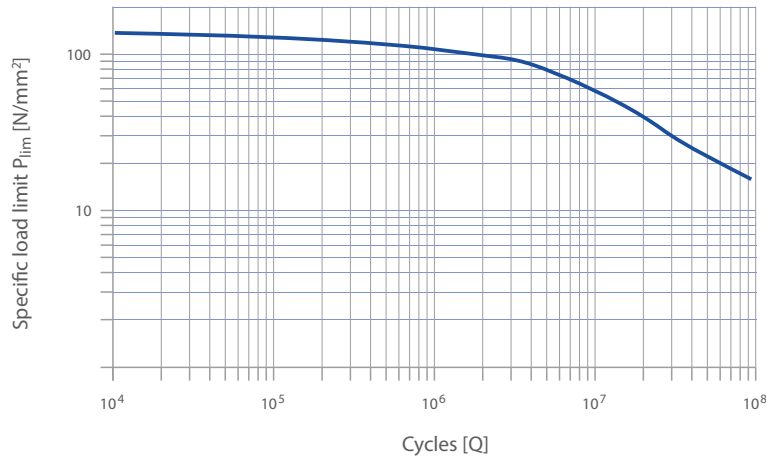

Fig. 9: HI-EX specific load limits p_{lim} under dynamic loads or oscillating conditions

5.2 SLIDING SPEED U

The sliding speed U [m/s] is calculated as follows:

CONTINUOUS ROTATION

CYLINDRICAL BUSH

$$(5.2.1) \quad U = \frac{D_i \cdot \pi \cdot N}{60 \cdot 10^3} \quad [\text{m/s}]$$

THRUST WASHER

$$(5.2.2) \quad U = \frac{\frac{D_o + D_i}{2} \cdot \pi \cdot N}{60 \cdot 10^3} \quad [\text{m/s}]$$

OSCILLATING MOVEMENT

CYLINDRICAL BUSH

$$(5.2.3) \quad U = \frac{D_i \cdot \pi}{60 \cdot 10^3} \cdot \frac{4\phi \cdot N_{osz}}{360} \quad [\text{m/s}]$$

THRUST WASHER

$$(5.2.4) \quad U = \frac{\frac{D_o + D_i}{2} \cdot \pi}{60 \cdot 10^3} \cdot \frac{4\phi \cdot N_{osz}}{360} \quad [\text{m/s}]$$

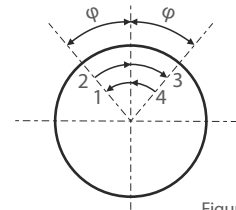

Figure 10: Oscillating cycle ϕ

The maximum permissible effective PU factor (ePU factor) for grease lubricated HI-EX® bearings is dependent upon the sliding speed as shown in Figure 11. For sliding speeds in excess of 2.5 m/s continuous oil lubrication is recommended.

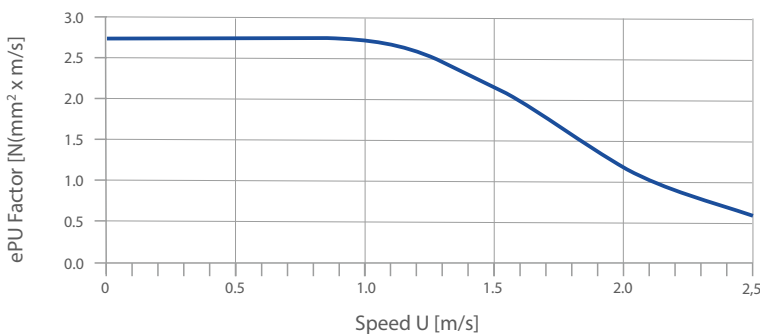

Fig. 11: Maximum ePU factor for grease lubrication

5.3 PU FACTOR

The useful operating life of a HI-EX® bearing is governed by the PU factor, which is calculated as follows:

$$(5.3.1) \quad [N/mm^2 \cdot m/s]$$

$$PU = P \cdot U$$

5.4 LOAD

In addition to its contribution to the PU factor the type and direction of the applied load also affects the performance of a HI-EX® bearing. This is accommodated in the calculation of the bearing service life by the speed/load application factor aQ shown in Figures 15 - 17.

TYPE OF LOAD

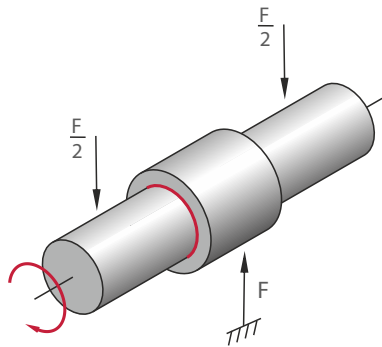

Fig. 12: Steady load, vertically downwards, bush stationary, shaft rotating. Lubricant drains to loaded area.

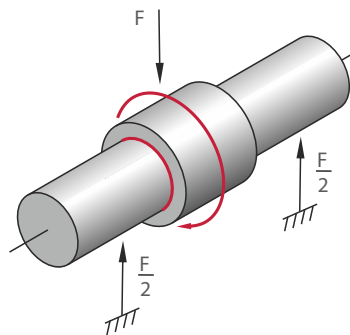

Fig. 13: Steady load, vertically upwards, bush stationary, shaft rotating. Lubricant drains away from loaded area

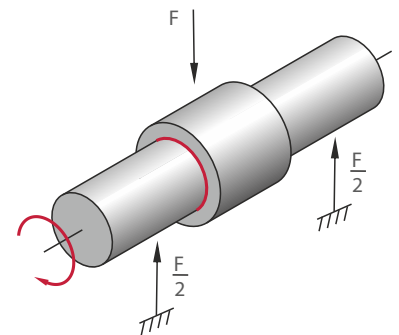

Fig. 14: Rotating load, shaft stationary, bush rotating

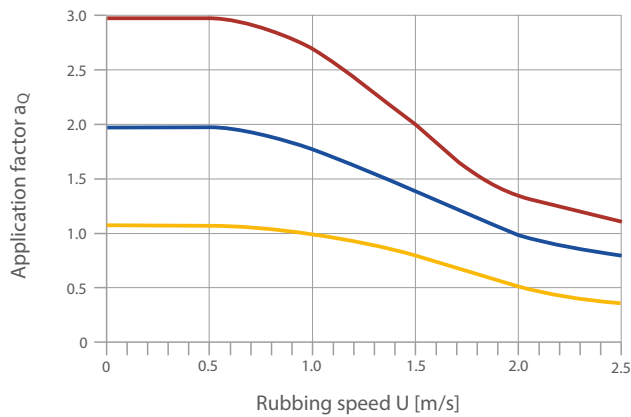

Fig. 15: Application factor aQ for MB range bushes - unmachined

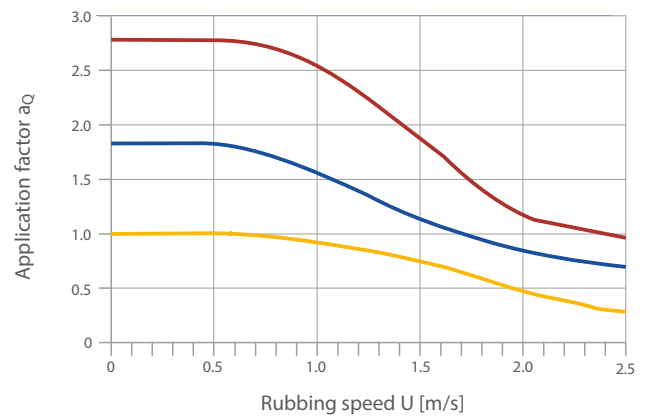

Fig. 16: Application factor aQ for PM range and MB range bushes - machined

- Rotating load
- Steady load vertically downwards
- Dynamic load or steady load not downwards

5 Design Factors

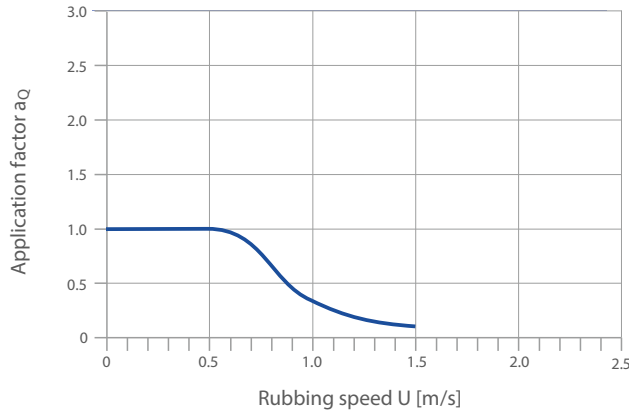

Fig. 17: Application factor a_Q for thrust washers

Note: $a_Q = 1$ for slideways

5.5 TEMPERATURE

The useful life of a HI-EX® bearing depends upon the operating temperature. The performance of grease lubricated HI-EX® decreases at bearing temperatures above 40 °C. This loss of performance is related to both material and lubricant effects.

For a given PU factor the operating temperature of the bearing depends upon the temperature of the surrounding environment and the heat dissipation properties of the housing.

In calculating the service life of HI-EX® these effects are accommodated by the application factor a_T shown in Fig. 18.

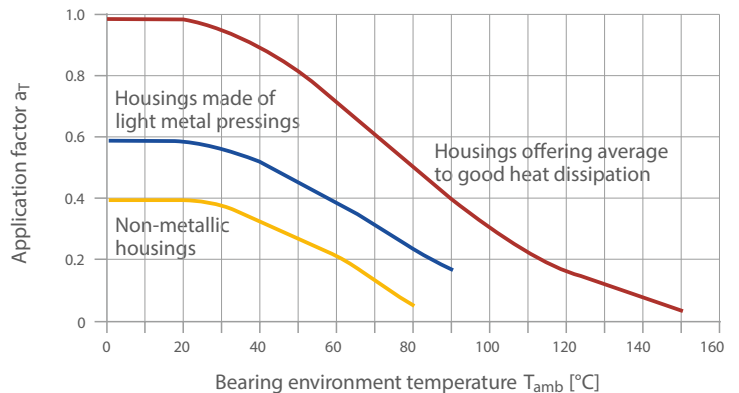

Fig. 18: HI-EX application factor a_T

5.6 MATING SURFACE

The wear rate of HI-EX® is strongly dependent upon the roughness of the mating counterface. For optimum bearing performance the mating surface should be ground to better than 0,4 $\mu m R_a$. This effect is accommodated by the mating surface finish application factor a_S shown in Fig. 19.

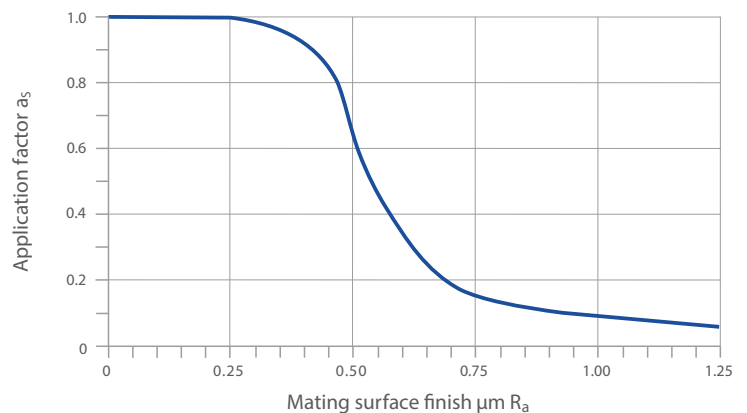

Fig. 19: HI-EX application factor a_S

5.7 BEARING SIZE

Frictional heat generated at the bearing surface and dissipated through the shaft and housing depends both on the operating conditions (i.e. PU factor) and the bearing size.

For a given PU condition a large bearing will run hotter than a smaller bearing. The bearing size factor a_B shown in Figure 20 takes account of this effect.

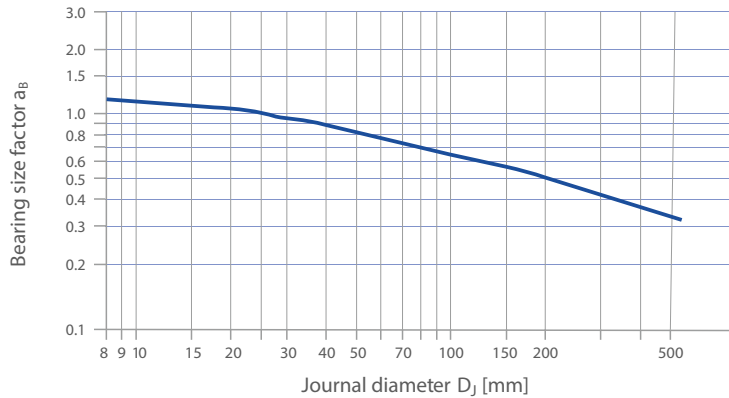

Fig. 20: Bearing size factor a_B

Note: $a_B = 1$ for slideways

5.8 ESTIMATION OF BEARING SERVICE LIFE WITH GREASE LUBRICATION

CALCULATION PARAMETERS

BUSHES	THRUST WASHERS	SLIDE PLATES	UNIT
Bearing diameter D_i	Bearing outside diameter D_o	Bearing length L	[mm]
Bearing width B	Bearing inside diameter D_i	Bearing width W	[mm]
OPERATING CONDITIONS			
Load	F		[N]
Rotational speed (continuous)	N		[1/min]
Oscillating frequency	N_{osc}		[1/min]
Angular movement about mean position	φ		[°]
Specific load limit	see table 5, page 13		[N/mm ²]
Application factor a_Q	see figure 15 - 17, page 15 - 16		[-]
Application factor a_T	see figure 18, page 16		[-]
Application factor a_s	see figure 19, page 16		[-]
Bearing size factor a_B	see figure 20, page 17		[-]

5 Design Factors

Calculate P from the equations in 5.1 on Page 13.

Calculate U from the equations in 5.2 on Page 14.

Calculate PU from the equation in 5.3 on Page 15.

CALCULATE HIGH LOAD FACTOR a_E

$$(5.8.1) \quad a_E = \frac{P_{lim} - P}{P_{lim}} \quad [-]$$

P_{lim} see Table 5, Page 13

Note:

If $a_E > 10000$, or $a_E < 0$, the bearing is overloaded.

CALCULATE EFFECTIVE PU FACTOR e_{PU}

$$(5.8.2) \quad e_{PU} = \frac{a_E \cdot PU}{a_B} \quad [-]$$

Note:

Check that e_{PU} is less than limit set in Fig. 11 for the sliding speed U. If NOT, increase the bearing length or use continuous lubrication.

ESTIMATE BEARING LIFE

If $e_{PU} \leq 1.0$, then

$$(5.8.3) \quad L_H = \frac{3000}{e_{PU}} \cdot a_Q \cdot a_T \cdot a_S \quad [h]$$

If $e_{PU} > 1.0$, then

$$(5.8.4) \quad L_H = \frac{3000}{(e_{PU})^{2.4}} \cdot a_Q \cdot a_T \cdot a_S \quad [h]$$

ESTIMATE REGREASING INTERVAL

$$(5.8.5) \quad L_{RG} = \frac{L_H}{2} \quad [h]$$

OSCILLATING MOTION

Calculate number of cycles

$$(5.8.6) \quad Z_T = L_{RG} \cdot n_{osc} \cdot 60 \cdot (R + 2) \quad [-]$$

DYNAMIC LOADS

Calculate number of cycles

$$(5.8.7) \quad C_T = L_{RG} \cdot C \cdot 60 \cdot (R + 2) \quad [-]$$

where R = Number of times bearing is regreased during total life required.

Check that Z_T (or C_T) is less than the total number of cycles Q given in Figure 9 for actual bearing specific load P.

If Z_T (or C_T) > Q, then life L_H will be limited by fatigue after Q cycles.

If Z_T (or C_T) < Q, then life L_H will be limited by wear after Z_T cycles.

If the estimated life or total cycles are insufficient or the regreasing intervals are too frequent, increase the bearing length or diameter, or consider drip feed or continuous oil lubrication, the quantity to be established by test.

5.9 WORKED EXAMPLES

PM CYLINDRICAL BUSH

Given:			
Load Details	Steady Load Direction: down	Inside Diameter D_i Length B	40 mm 30 mm
Shaft	Steel, $R_a = 0.4 \mu\text{m}$ Temperature 85°C	Bearing Load F Rotational Speed N	20.000 N $30 \cdot 1/\text{min}$
Housing	Light metal - poor heat dissipation		

Calculation Constants and Application Factors	
Specific Load Limit P_{lim} at 85°C	81.5 N/mm^2 (Table 5, Page 13)
Application Factor a_T	0.2 (Fig. 18, Page 16)
Mating Surface Application Factor a_S	0.85 (Fig. 19, Page 16)
Bearing Size Factor a_B for $\varnothing 40$	0.95 (Fig. 20, Page 17)
Application Factor for PM bush a_Q	1.8 (Fig. 16, Page 15)

Calculation	Ref	Value
Specific Load p [N/mm ²]	(5.1.1) Page 13	$P = \frac{F}{D_i \cdot B} = \frac{20,000}{40 \cdot 30} = 16.67$
Sliding Speed U [m/s]	(5.2.1) Page 14	$U = \frac{D_i \cdot \pi \cdot N}{60 \cdot 10^3} = \frac{40 \cdot 3.14 \cdot 30}{60 \cdot 10^3} = 0.063$
High Load Factor a_E [-] must be > 0	(5.8.1) Page 18	$a_E = \frac{P_{lim}}{P_{lim} - P} = \frac{81.5}{81.5 - 16.67} = 1.25$
ePU Factor [-]	(5.8.2) Page 18	$ePU = \frac{a_E \cdot PU}{a_B} = \frac{1.25 \cdot 16.67 \cdot 0.063}{0.95} = 1.328$
Life L_H [h] for $ePU > 1$	(5.8.4) Page 18	$L_H = \frac{3000}{ePU^{2.4}} \cdot a_Q \cdot a_T \cdot a_S$ $= \frac{3000}{1.382^{2.4}} \cdot 1.8 \cdot 0.2 \cdot 0.85 = 434$
L_{RG} [h]	(5.8.5) Page 18	$L_{RG} = \frac{L_H}{2} = \frac{434}{2} = 217$

PM CYLINDRICAL BUSH

Given:			
Load Details	Steady Load Direction: up	Inside Diameter D_i Length B	100 mm 60 mm
Shaft	Steel, $R_a = 0.3 \mu\text{m}$ Temperature 80°C	Bearing Load F Rotational Speed N	45.000 N $35 \cdot 1/\text{min}$
	good heat dissipation		

Calculation Constants and Application Factors	
Specific Load Limit P_{lim} at 40°C	90 N/mm^2 (Table 5, Page 13)
Application Factor a_T	0.5 (Fig. 18, Page 16)
Mating Surface Application Factor a_S	1.0 (Fig. 19, Page 16)
Bearing Size Factor a_B for $\varnothing 100$	0.65 (Fig. 20, Page 17)
Application Factor for PM bush a_Q	1.0 (Fig. 16, Page 15)

Calculation	Ref	Value
Specific Load p [N/mm ²]	(5.1.1) Page 13	$P = \frac{F}{D_i \cdot B} = \frac{45,000}{100 \cdot 60} = 7.5$
Sliding Speed U [m/s]	(5.2.1) Page 14	$U = \frac{D_i \cdot \pi \cdot N}{60 \cdot 10^3} = \frac{100 \cdot 3.14 \cdot 35}{60 \cdot 10^3} = 0.183$
High Load Factor a_E [-] must be > 0	(5.8.1) Page 18	$a_E = \frac{P_{lim}}{P_{lim} - P} = \frac{90}{90 - 7.5} = 1.091$
ePU Factor [-]	(5.8.2) Page 18	$ePU = \frac{a_E \cdot PU}{a_B} = \frac{1.091 \cdot 7.5 \cdot 0.183}{0.65} = 2.307$
Life L_H [h] for $ePU > 1$	(5.8.4) Page 18	$L_H = \frac{3000}{ePU^{2.4}} \cdot a_Q \cdot a_T \cdot a_S$ $= \frac{3000}{2.307^{2.4}} \cdot 1.0 \cdot 1.0 \cdot 0.5 = 202$
L_{RG} [h]	(5.8.5) Page 18	$L_{RG} = \frac{L_H}{2} = \frac{202}{2} = 101$

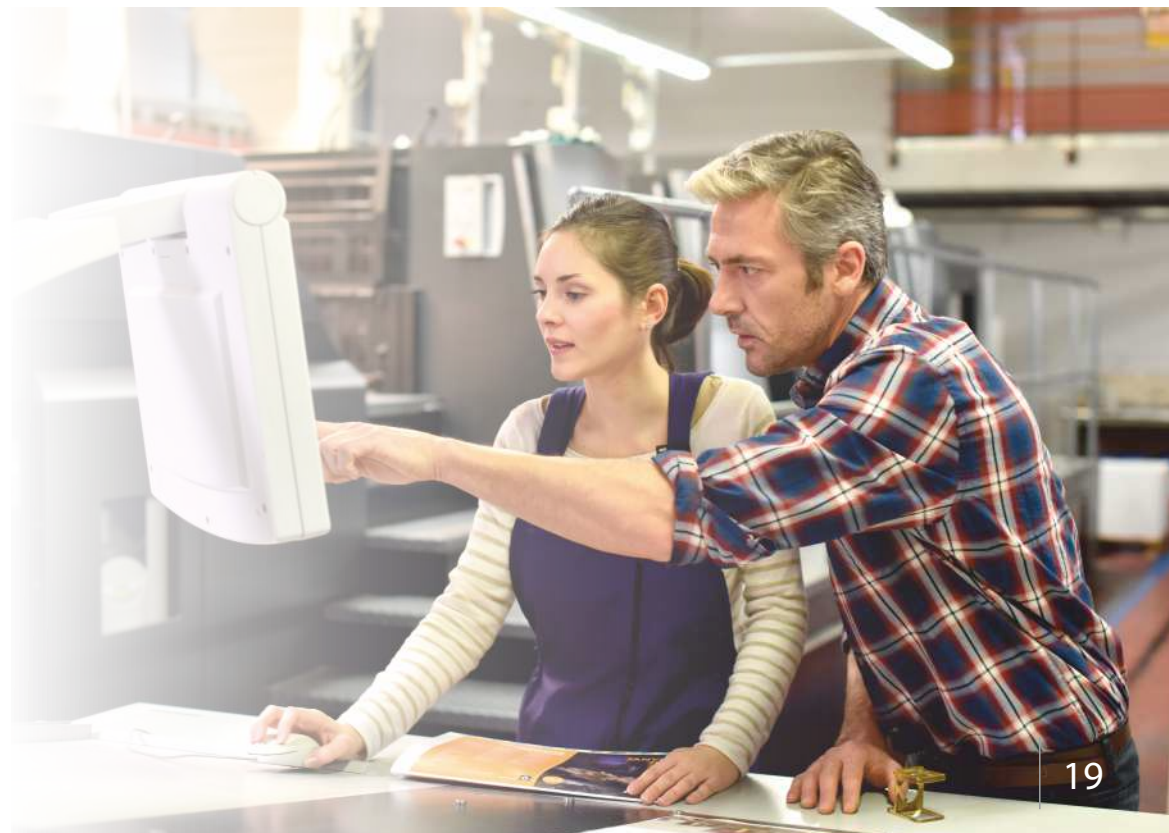

5 Design Factors

MB CYLINDRICAL BUSH

Given:			
Load Details	Steady Load oscill. Direction: down	Inside Diameter D_i Length B	80 mm 40 mm
Shaft	Steel, $R_a = 0.3 \mu\text{m}$ Temperature 85°C	Bearing Load F Osc. mov. freq. n_{osc}	200.000 N 1.11 · 1/min
Housing	Light metal - poor heat dissipation	Angle φ	20°

Calculation Constants and Application Factors	
Specific Load Limit P_{lim}	140 N/mm ² (Table 5, Page 13)
Application Factor a_T	0.6 (Fig. 18, Page 16)
Mating Surface Application Factor a_S	1.0 (Fig. 19, Page 16)
Bearing Size Factor a_B for $\varnothing 80$	0.75 (Fig. 20, Page 17)
Application Factor for PM bush a_Q	1.8 (Fig. 16, Page 15)

Calculation	Ref	Value
Specific Load P [N/mm ²]	(5.1.1) Page 13	$P = \frac{F}{D_i \cdot B} = \frac{200,000}{80 \cdot 40} = 62.5$
Sliding Speed U [m/s]	(5.2.3) Page 14	$U = \frac{D_i \cdot \pi}{60 \cdot 10^3} \cdot \frac{4\varphi \cdot N_{osc}}{360}$ $= \frac{80 \cdot \pi}{60,000} \cdot \frac{4 \cdot 20 \cdot 1.11}{360} = 0,001$
High Load Factor a_E [-] must be > 0	(5.8.1) Page 18	$a_E = \frac{P_{lim}}{P_{lim} - P} = \frac{140}{140 - 62.5} = 1.806$
ePU Factor [-]	(5.8.2) Page 18	$ePU = \frac{a_E \cdot PU}{a_B} = \frac{1.806 \cdot 62.5 \cdot 0.001}{0.75} = 0.151$
Life L_H [h] for $ePU < 1$	(5.8.3) Page 18	$L_H = \frac{3000}{ePU} \cdot a_Q \cdot a_T \cdot a_S$ $= \frac{3000}{0.151} \cdot 1.8 \cdot 0.6 \cdot 1.0 = 21,456$
L_{RG} [h]	(5.8.5) Page 18	$L_{RG} = \frac{L_H}{2} = \frac{21,456}{2} = 10,728$
Z_T [-]	(5.8.6) Page 18	$Z_T = L_{RG} \cdot N_{osc} \cdot 60 \cdot (R + 2)$ $= 10,728 \cdot 1.11 \cdot 60 \cdot 2 = 1.43 \cdot 10^6$ Q for $P = 62.5 = 1.43 \cdot 10^6$; $Z_T > Q$, therefore bearing fails by fatigue after $1.43 \cdot 10^6$ cycles

MB CYLINDRICAL BUSH

Given:			
Load Details	Steady Load Direction: down	Inside Diameter D_i Outside Diameter D_o	40 mm 78 mm
Counterface	Steel, $R_a = 0.2 \mu\text{m}$ Temperature 50°C	Bearing Load F Rotational Speed N	50.000 N 25 · 1/min
Housing	Light metal - poor heat dissipation		

Calculation Constants and Application Factors	
Specific Load Limit p_{lim}	90 N/mm ² (Table 5, Page 13)
Application Factor a_T for 50°C	0.5 (Fig. 18, Page 16)
Mating Surface Application Factor a_S	1.0 (Fig. 19, Page 16)
Bearing Size Factor a_B for $\varnothing 40$	0.95 (Fig. 20, Page 17)
Applic. Factor for Thrust Washer a_Q	1.0 (Fig. 17, Page 16)

Calculation	Ref	Value
Specific Load P [N/mm ²]	(5.1.1) Page 13	$P = \frac{4 \cdot F}{\pi \cdot (D_o^2 - D_i^2)} = \frac{4 \cdot 50,000}{\pi \cdot (78^2 - 40^2)} = 14.2$
Sliding Speed U [m/s]	(5.2.2) Page 14	$U = \frac{D_o + D_i}{2} \cdot \pi \cdot N$ $= \frac{78 + 40}{2} \cdot \pi \cdot 25$ $= \frac{2}{60 \cdot 10^3} = 0.0772$
High Load Factor a_E [-] must be > 0	(5.8.1) Page 18	$a_E = \frac{P_{lim}}{P_{lim} - P} = \frac{90}{90 - 14.2} = 1.187$
ePU Factor [-]	(5.8.2) Page 18	$ePU = \frac{a_E \cdot PU}{a_B} = \frac{1.187 \cdot 14.2 \cdot 0.0772}{0.95} = 1.37$
Life L_H [h] for $ePU < 1$	(5.8.4) Page 18	$L_H = \frac{3000}{ePU^{2.4}} \cdot a_Q \cdot a_T \cdot a_S$ $= \frac{3000}{1.37^{2.4}} \cdot 1.0 \cdot 0.5 \cdot 1.0 = 704$
L_{RG} [h]	(5.8.5) Page 18	$L_{RG} = \frac{L_H}{2} = \frac{704}{2} = 352$

6 Bearing Assembly

6.1 DIMENSIONS AND TOLERANCES

For optimum performance it is essential that the correct running clearance is used and that both the diameter of the shaft and the bore of the housing are finished to the limits given in the tables.

If the bearing housing is unusually flexible the bush will not close in by the calculated amount and the running clearance will be more than the optimum. In these circumstances the housing should be bored slightly undersize or the journal diameter increased, the correct size being determined by experiment.

6.2 TOLERANCES FOR MINIMUM CLEARANCE

GREASE LUBRICATION

The minimum clearance required for satisfactory performance of HI-EX® depends upon the pv factor, the sliding speed and the environmental temperature, any one or combination of which may reduce the diametral clearance in operation due to inward thermal expansion of the HI-EX® polymer lining. It is therefore necessary to compensate for this.

Figure 21 shows the minimum diametral clearance plotted stepped against journal diameter at an ambient 20 °C. Where the stepped lines show a change of clearance for a given journal diameter, the lower value is used.

The superimposed straight lines indicate the minimum permissible diametral clearance for various values of PUu (Figure 21), where PU is calculated as in 5.3 on page 15, and u is a sliding speed factor for speeds in excess of 0.5 m/s given in Figure 22.

If the clearance indicated for a pUu factor lies below the stepped lines the recommended standard shaft may be used. If above, the shaft size must be reduced to obtain the clearance indicated on the vertical axis of the relevant figure.

Under slow speed and high load conditions it may be possible to achieve satisfactory performance with diametral clearances less than those indicated. But adequate prototype testing is recommended in such cases.

6 Bearing Assembly

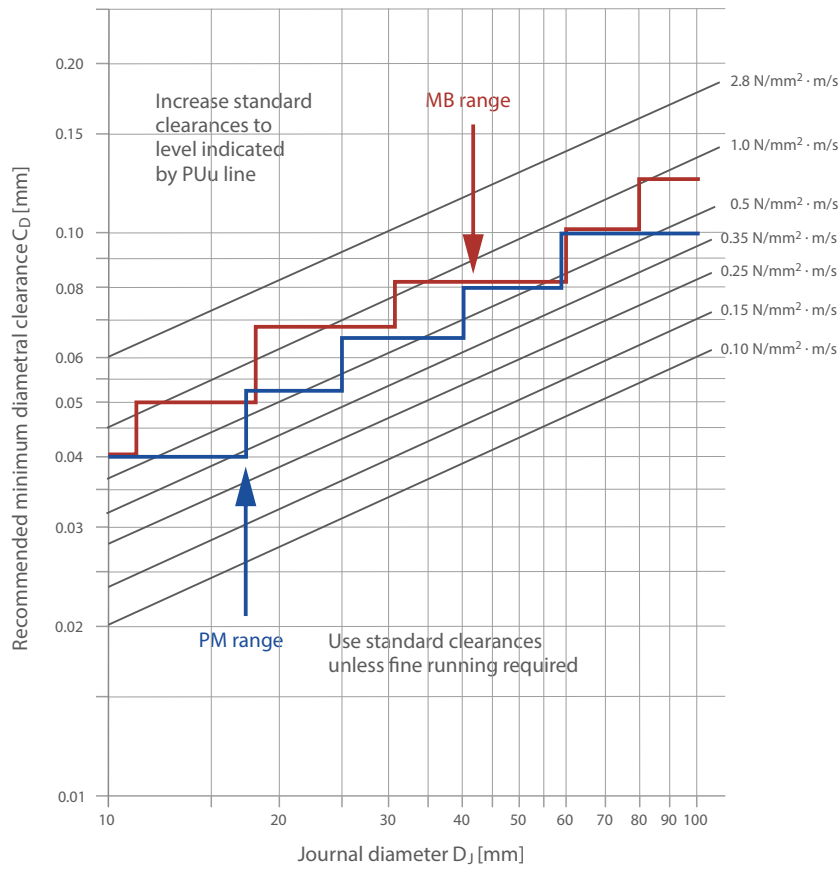

Fig. 21: Minimum clearance for PM prefinished and MB machinable range machined to H7 bore

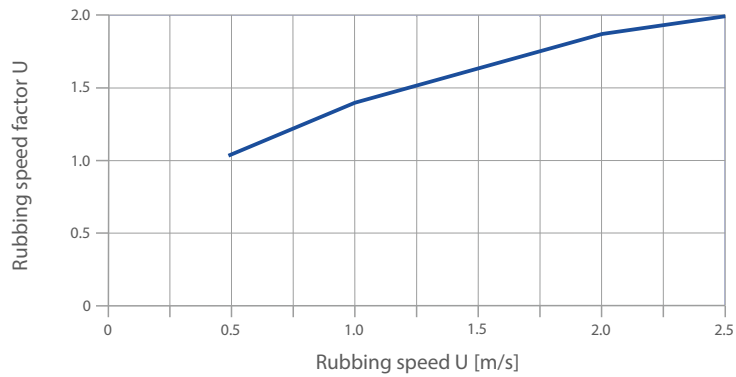

Fig. 22: Rubbing speed factor U

FLUID LUBRICATION

The minimum clearance required for journal bearings operating under hydrodynamic or mixed film conditions for a range of shaft rotational speeds and diameters is shown in Figure 23. It is recommended that the bearing performance under minimum clearance conditions be confirmed by testing if possible.

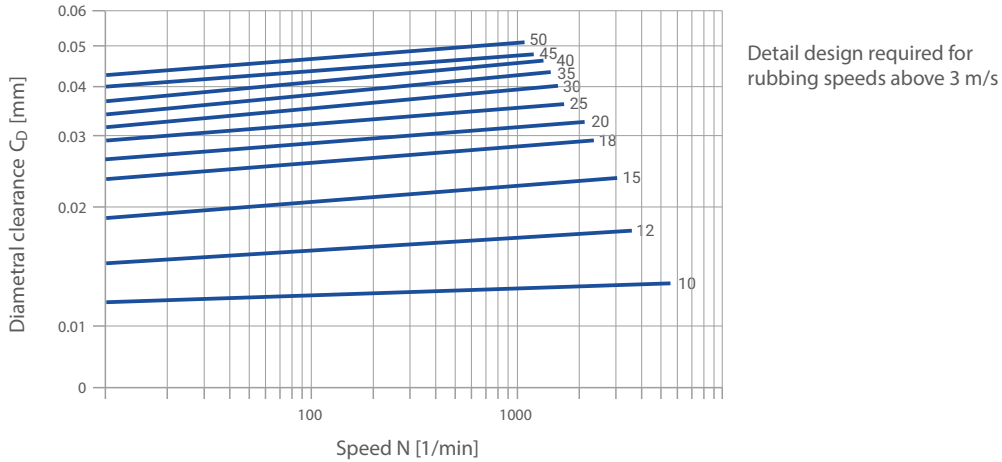

Fig. 23: HI-EX minimum clearances - bush diameters D_i 10 - 50 mm

ALLOWANCE FOR THERMAL EXPANSION

For operation in high temperature environments the clearance should be increased by the amounts indicated by Figure 24 to compensate for the inward thermal expansion of the bearing lining.

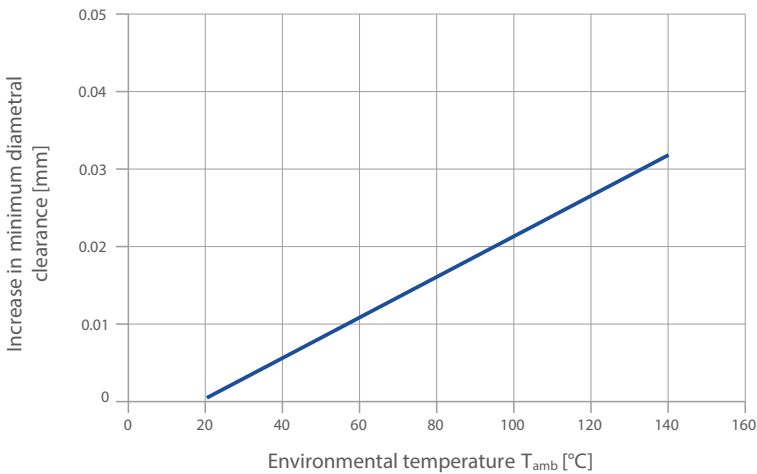

Fig. 24: Recommended increase in diametral clearance

If the housing is non-ferrous then the bore should be reduced by the amounts given in Table 6, in order to give an increased interference fit to the bush, with a similar reduction in the journal diameter additional to that indicated by Figure 24.

6 Bearing Assembly

HOUSING MATERIAL	REDUCTION IN HOUSING DIAMETER PER 100°C RISE	REDUCTION IN SHAFT DIAMETER PER 100°C RISE
Aluminium alloys	0.1 %	0.1 % + values from Fig. 24
Copper base alloys	0.05 %	0.05 % + values from Fig. 24
Steel and cast iron	–	values from Fig. 24
Zinc base alloys	0.15 %	0.15 % + values from Fig. 24

Table 6: Allowance for high temperature

6.3 COUNTERFACE DESIGN

HI-EX® bearings may be used with all conventional mating surface materials. Hardening of steel journals is not required unless abrasive dirt is present or if the projected bearing life is in excess of 2000 hours, in which cases a minimum shaft hardness of 350HB is recommended.

A ground surface finish of better than $0.4 \mu\text{m } R_a$ is recommended. The final direction of machining of the mating surface should preferably be the same as the direction of motion relative to the bearing in service.

HI-EX® is normally used in conjunction with ferrous journals and thrust faces, but in damp or corrosive surroundings stainless steel, hard chromium plated mild steel, or alternatively WH shaft sleeves are recommended. When plated mating surfaces are specified the plating should possess adequate strength and adhesion, particularly if the bearing is to operate with high fluctuating loads.

The shaft or thrust collar used in conjunction with the HI-EX® bush or thrust washer must extend beyond the bearing surface in order to avoid cutting into it. The mating surface must also be free from grooves or flats, the end of the shaft should be given a lead-in chamfer and all sharp edges or projections which may damage the soft polymer lining of the HI-EX® must be removed.

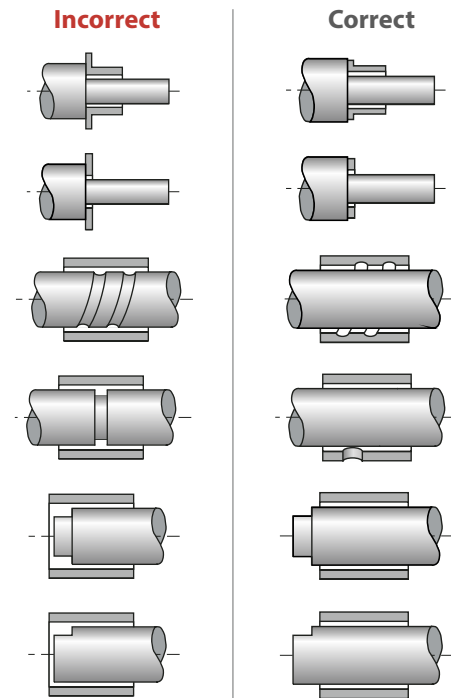

Fig. 25: Counterface Design

6.4 INSTALLATION

IMPORTANT NOTE:

Care must be taken to ensure that the HI-EX® lining material is not damaged during the installation.

FITTING OF BUSHES

The bush is inserted into its housing with the aid of a stepped mandrel, preferably made from case hardened mild steel, as shown in Figure 26. The following should be noted to avoid damage to the bearing:

- Housing diameter is as recommended
- 15-30 deg lead-in chamfer on housing
- The bush must be square to the housing
- Light smear of oil on bush OD

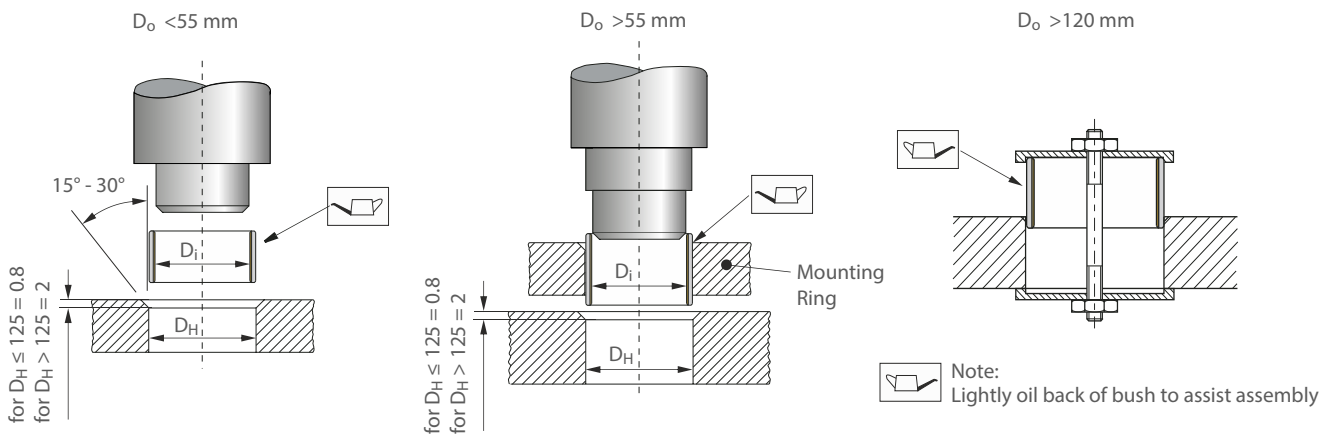

Fig. 26: Fitting of cylindrical bushes

INSERTION FORCES

Figure 27 gives an indication of the maximum insertion force required to correctly install standard HI-EX® bushes.

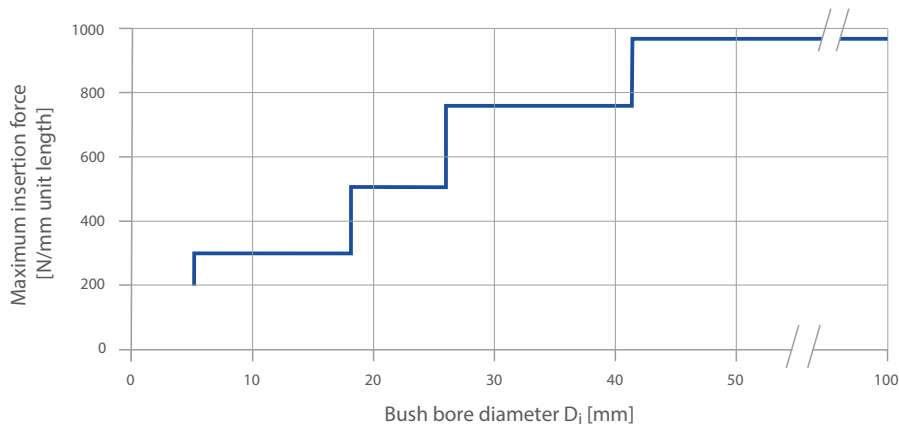

Fig. 27: Maximum Insertion Force F_i

6 Bearing Assembly

ALIGNMENT

Accurate alignment is an important consideration for all bearing assemblies, but is particularly so for dry bearings because there is no lubricant to spread the load. With HI-EX® bearings misalignment over the length of a bush (or pair of bushes), or over the diameter of a thrust washer should not exceed 0,020 mm as illustrated in Figure 28.

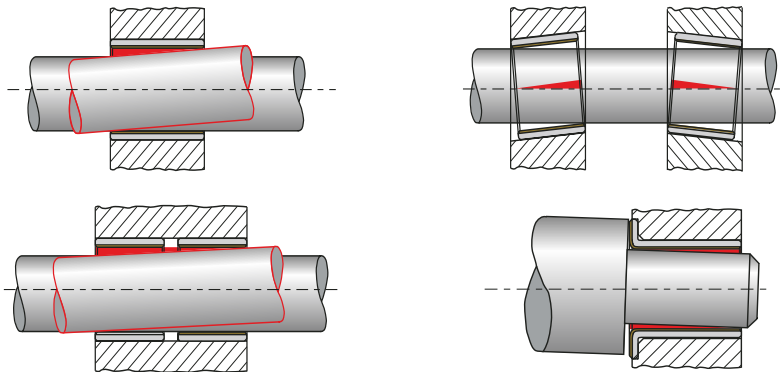

Fig. 28: Alignment

SEALING

While HI-EX® can tolerate the ingress of some contaminant materials into the bearing without loss of performance, where there is the possibility of highly abrasive material entering the bearing, a suitable sealing arrangement, as illustrated in Figure 29 should be provided.

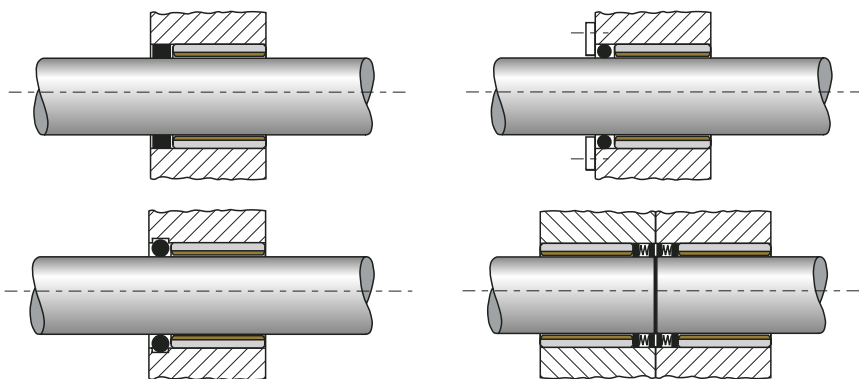

Fig. 29: Recommended sealing arrangements

AXIAL LOCATION

Where axial location is necessary, it is generally advisable to fit HI-EX® thrust washers in conjunction with HI-EX® bushes, even when the axial loads are low. Experience has shown that fretting debris from unsatisfactory locating surfaces can enter an adjacent HI-EX® bush and adversely affect the bearing life and performance.

FITTING OF THRUST WASHERS

HI-EX® thrust washers should be located on the outside diameter in a recess as shown in Fig. 30. The inside diameter must be clear of the shaft in order to prevent contact with the steel backing of the HI-EX® material. The recess diameter should be 0.125 mm larger than the washer diameter and the depth as given in the product tables.

If there is no recess for the thrust washer one of the following methods of fixing may be used:

- Two dowel pins
- Two screws
- Adhesive

IMPORTANT NOTE

- Dowel pins should be recessed 0.25 mm below the bearing surface
- Screws should be countersunk 0.25 mm below the bearing surface
- HI-EX® must not be heated above 250 °C
- Contact adhesive manufacturers for guidance on the selection of suitable adhesives
- Protect the bearing surface to prevent contact with adhesive
- Ensure the washer ID does not touch the shaft after assembly
- Ensure that the washer is mounted with the steel backing to the housing

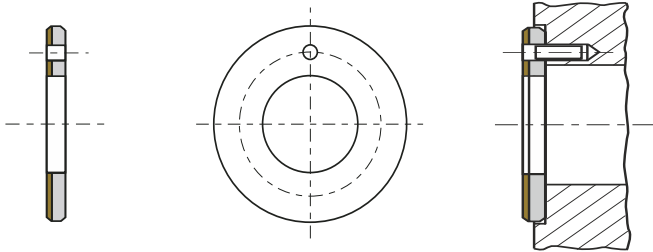

Fig. 30: Installation of thrust-washer

SLIDEWAYS

HI-EX® strip material for use as slideway bearings should be installed using one of the following methods:

- Countersunk screws
- Adhesives
- Mechanical location

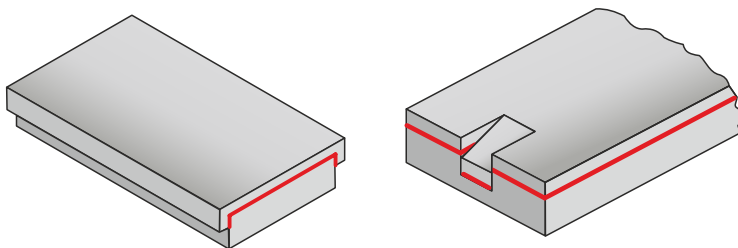

Fig. 31: Mechanical location of HI-EX slideplates

7 Machining

7.1 MACHINING PRACTICE

The PEEK polymer lining of HI-EX® has good machining characteristics and can be treated as a free cutting brass in most respects. The indents in the bearing surface may lead to the formation of burrs or whiskers due to the resilience of the lining material, but this can be avoided by using machining methods which remove the lining as a ribbon, rather than a narrow thread.

When machining HI-EX® it is recommended that not more than 0.125 mm is removed from the lining thickness in order to ensure that the lubricant capacity of the indents remaining after machining is not significantly reduced.

Boring, reaming and broaching are all suitable machining methods for use with HI-EX®. The recommended tool material is high speed steel or tungsten carbide, respectively diamonds for long tool service times.

7.2 BORING

Figure 32 illustrates a recommended boring tool.

- Mounted: 90° to the direction of feed.
 - Tip radius >1.5 mm.
- Side rake: 30° will produce the ribbon effect.
- Cutting speed: 2.0 - 4.5 m/s.
- Feed: 0.05 - 0.025 mm for cuts of 0.125 mm (the lower feeds being used with the higher cutting speeds).
- Satisfactory finishes can usually be obtained machining dry.
- Air blast may facilitate swarf removal.
- The use of coolant is not detrimental.

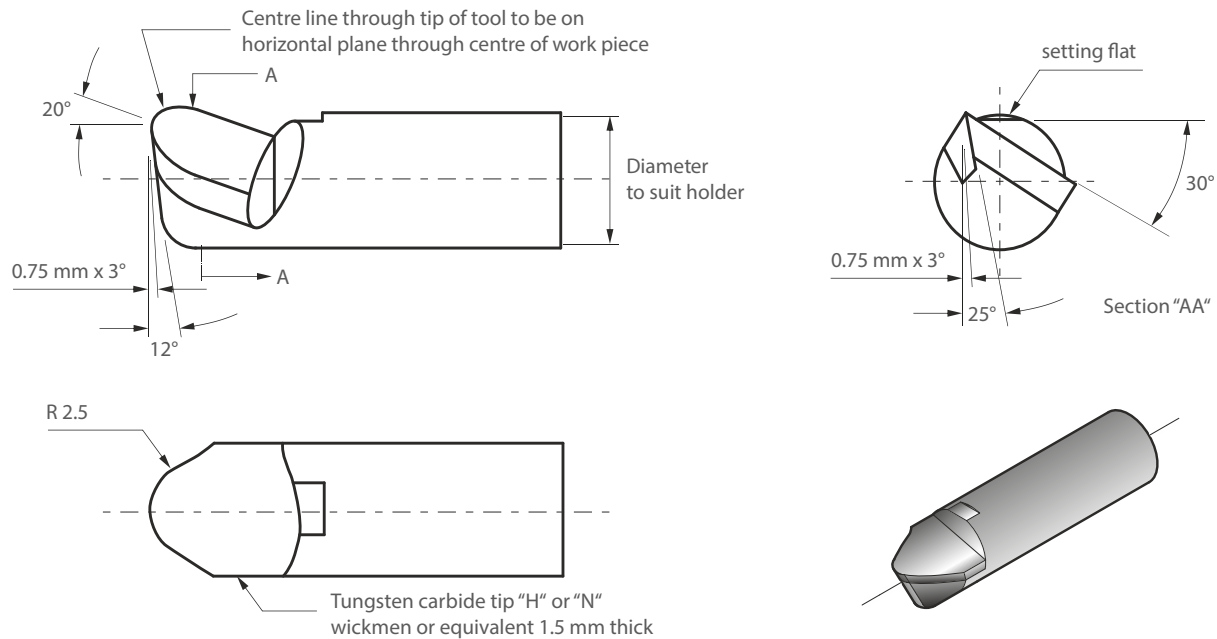

Fig. 32: Boring tool for HI-EX

7.3 REAMING

HI-EX® bushes can be reamed satisfactorily by hand with a straight-fluted expanding reamer. For best results the reamer should be sharp, the cut 0,025 - 0,050 mm and the feed slow. Where hand reaming is not desired machining speeds of about 0.05 m/s are recommended with the cuts and feeds as for boring.

7.4 BROACHING

Fig. 33 shows broaches suitable for finishing bushes up to 65 mm diameter. The broach should be used dry, at a speed of 0.1 - 0.5 m/s.

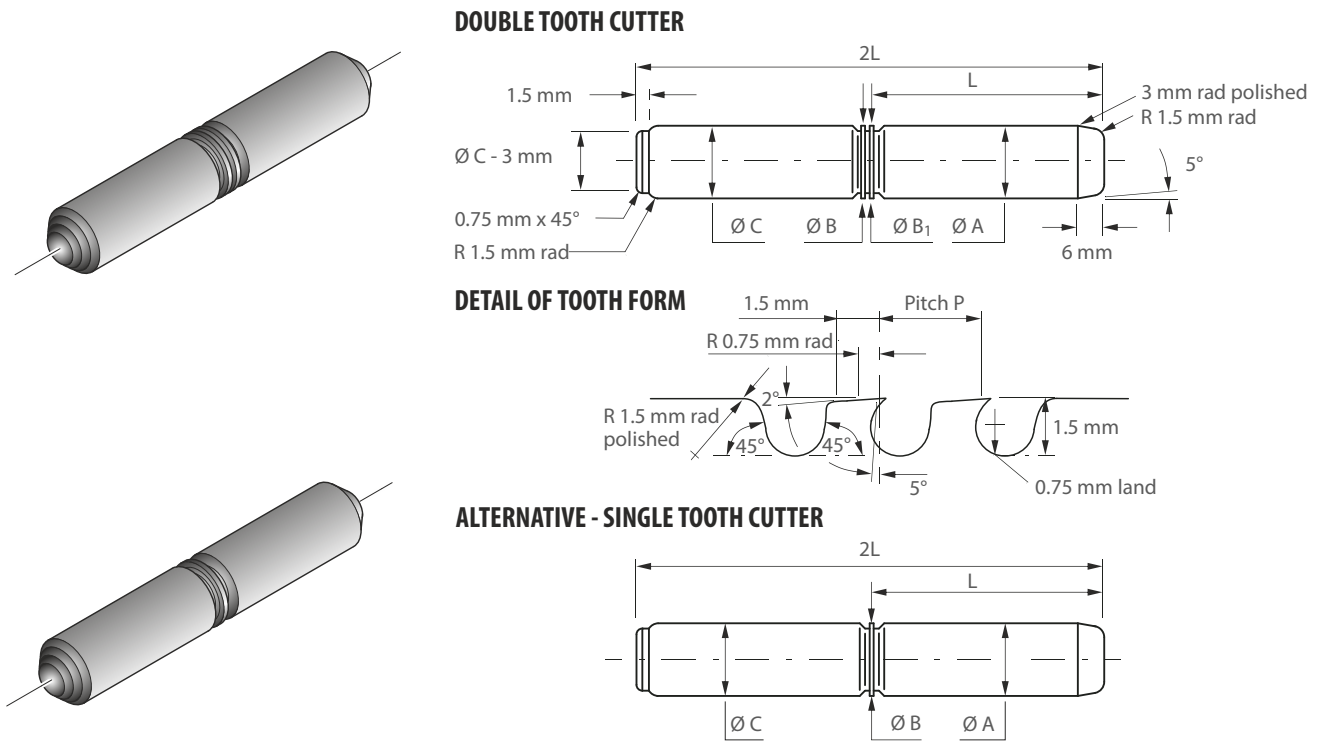

BUSH WIDTH B OVER	TO	PITCH P
10	13	3
13	20	4
20	30	5
30	50	5,5
50	70	6
70	95	7
95	130	8

DIAMETER		
Ø A	Min. ass. bore	+0.013 +0
Ø B	Nominal bore	+0.038 +0.025
Ø C	Nominal bore	+0.015 +0.005
Min. ass. bore = $D_{0 \text{ min}} - 2 \cdot S_{3 \text{ max}}$		
Nominal bore = min. finished bore		
Ø B ₁ *	Nominal bore	-0.065 -0.076

MIN. LENGTH OF PILOT GUIDE L _{min}	
Single bush	B + 6
2 or more bushes in line	B + 6 + bush spacing

Fig. 33: Suitable broaches for HI-EX

* First tooth of double tooth cutter

Use the single tooth version where the bush is less than 25 mm long, and the double tooth broach for longer bushes or for two or more bushes together.

If it is necessary to make up a special form of broach the following points should be noted:

- Adequate provision should be made for locating the bush by providing a pilot to suit the bore of the bush when pressed home. A rear support shoulder should locate in the broached bore of the bush after cutting. Alternatively, special guides may be provided external to the workpiece.

7 Machining

- If two bushes are to be broached in line, then the pilot guide and rear support should be longer than the distance between the two bushes.
- For large bushes it may be necessary to provide axial relief along the length of the pilot guide and rear support, in order to reduce the broaching forces.
- Unless a guided broach is used, the tool will follow the initial bore alignment of the bush, broaching cannot improve concentricity and parallelism unless external guides are used.
- In general owing to the variation in wall thickness of large diameter bushes, broaching is not suitable for finishing bores of more than 60 mm diameter unless external guides are used.

7.5 VIBROBROACHING

This technique may also be used. A single cutter is propelled with progressive reciprocating motion with a vibration frequency of typically 50 Hz. The cutter should have a primary rake of 1.5° for 0.5 mm. A cut of 0.25 mm on diameter may be made at an average cutting speed of 0.15 m/s to give a surface finish of better than $0.8 \mu\text{m } R_a$, which is acceptable.

7.6 MODIFICATION OF COMPONENTS

The modification of HI-EX® bearing components requires no special procedures. In general it is more satisfactory to perform machining or drilling operations from the polymer lining side in order to avoid burrs. When cutting is done from the steel side, the minimum cutting pressure should be used and care taken to ensure that any steel or bronze particles protruding into the remaining bearing material, and all burrs, are removed.

7.7 DRILLING OIL HOLES

Bushes should be adequately supported during the drilling operation to ensure that no distortion is caused by the drilling pressure.

7.8 CUTTING STRIP MATERIAL

HI-EX® strip material may be cut to size by any one of the following methods. Care must be taken to protect the bearing surface from damage and to ensure that no deformation of the strip occurs.

- Using side and face cutter, or slitting saw, with the strip held flat and securely on a horizontal milling machine
- Cropping
- Guillotine (For widths less than 90 mm only)
- Water-jet cutting, laser cutting

8 Electroplating

HI-EX® COMPONENTS

To provide corrosion protection the mild steel backing of HI-EX® may be electroplated with most of the conventional electroplating metals including the following:

- zinc ISO 2081-2
- nickel ISO 1456-8
- hard chromium ISO 1456-8

For the harder materials if the specified plating thickness exceeds approximately 5µm then the housing diameter should be increased by twice the plating thickness in order to maintain the correct assembled bearing bore size.

Where electrolytic attack is possible tests should be conducted to ensure that all the materials in the bearing environment are mutually compatible.

MATING SURFACES

HI-EX® can be used against hard chrome plated materials and care should be taken to ensure that the recommended shaft sizes and surface finish are achieved after the plating process.

NOTE

The parts shown in the following tables are not available from stock.

9 Standard Products

9.1 PM HI-EX® CYLINDRICAL BUSHES

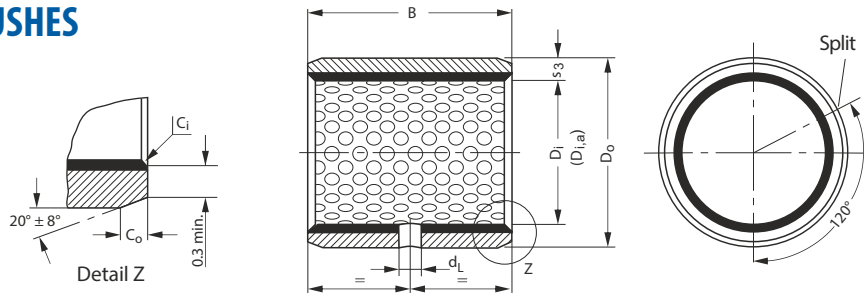

Dimensions and Tolerances according to ISO 3547 and GGB-Specifications
 Note: For $D_i \leq 40$ mm, bush backing is tin flashed; for $D_i > 40$ mm, bush backing is copper flashed

OUTSIDE C_0 AND INSIDE C_i CHAMFERS

WALL THICKNESS S_3	C_0 (a)		C_i (b)
	MACHINED	ROLLED	
1	0.6 ± 0.4	0.6 ± 0.4	-0.1 to -0.5
1.5	0.6 ± 0.4	0.6 ± 0.4	-0.1 to -0.7

WALL THICKNESS S_3	C_0 (a)		C_i (b)
	MACHINED	ROLLED	
2	1.2 ± 0.4	1.0 ± 0.4	-0.1 to -0.7
2.5	1.8 ± 0.6	1.2 ± 0.4	-0.2 to -1.0

(a) = chamfer C_0 machined or rolled at the opinion of the manufacturer
 (b) = C_i can be a radius or a chamfer in accordance with ISO 13715

PART NO.	NOMINAL DIAMETER		WALL THICKNESS S_3 max. min.	WIDTH B max. min.	SHAFT $\emptyset D_j$ [h8] max. min.	HOUSING $\emptyset D_H$ [H7] max. min.	BUSH $\emptyset D_{i,a}$ ASSEMBLY IN H7 HOUSING max. min.	CLEARANCE C_D max. min.	OIL HOLE $\emptyset d_L$
	D_i	D_o							
PM0808HX	8	10	0.980 0.955	8.25	8.000 7.978	10.015 10.000	8.105 8.040	0.127 0.040	No hole
PM0810HX				7.75					
PM0812HX				10.25					
PM1010HX	9.75								
PM1012HX	12.25								
PM1015HX	11.75								
PM1020HX	10.25	10.000 9.978		H7	12.018 12.000	10.108 10.040	0.130 0.040	3	
PM1210HX	9.75								
PM1212HX	12.25								
PM1215HX	11.75								
PM1220HX	15.25								
PM1225HX	14.75								
PM1415HX	20.25	14.000 13.973	H7	16.018 16.000	14.108 14.040	0.135 0.040	4		
PM1420HX	19.75								
PM1425HX	25.25								
	24.75								

All dimensions in mm

PART NO.	NOMINAL DIAMETER		WALL THICKNESS S_3 max. min.	WIDTH B max. min.	SHAFT Ø D_j [h8] max. min.	HOUSING Ø D_H [H7] max. min.	BUSH Ø $D_{i,a}$ ASSEMBLY IN H7 HOUSING max. min.	CLEARANCE C_D max. min.	OIL HOLE Ø d_L
	D_i	D_o							
PM1508HX	15	17	0.980 0.955	8.25	15.000 14.973	17.018 17.000	15.108 15.040	0.135 0.040	3
PM1510HX				7.75					
PM1512HX				10.25					
PM1515HX				9.75					
PM1520HX				12.25					
PM1525HX				11.75					
PM1615HX	16	18	0.980 0.955	15.25	16.000 15.973	18.018 18.000	16.108 16.040	0.135 0.040	4
PM1620HX				14.75					
PM1625HX				20.25					
PM1815HX	18	20	0.980 0.955	15.25	18.000 17.973	20.021 20.000	18.111 18.040	0.135 0.040	4
PM1820HX				14.75					
PM1825HX				20.25					
PM2010HX	20	23	1.475 1.445	10.25	20.000 19.967	23.021 23.000	20.131 20.050	0.164 0.050	6
PM2015HX				9.75					
PM2020HX				15.25					
PM2025HX				14.75					
PM2030HX				20.25					
PM2215HX				19.75					
PM2220HX	25.25								
PM2225HX	24.75								
PM2230HX	22	25	1.475 1.445	30.25	22.000 21.967	25.021 25.000	22.131 22.050	0.164 0.050	6
PM2240HX				29.75					
PM2245HX				30.25					
PM2415HX	24	27	1.475 1.445	15.25	24.000 23.967	27.021 27.000	24.131 24.050	0.164 0.050	6
PM2420HX				14.75					
PM2425HX				20.25					
PM2430HX				19.75					
PM2515HX	25	28	1.475 1.445	15.25	25.000 24.967	28.021 28.000	25.131 25.050	0.164 0.050	6
PM2520HX				14.75					
PM2525HX				20.25					
PM2530HX				19.75					
PM283130HX				25.25					
PM2820HX	28	31	1.970 1.935	30.25	28.000 27.967	31.025 31.000	28.135 28.050	0.168 0.050	6
PM2825HX				29.75					
PM2830HX				20.25					
				19.75					
				25.25		32.025	28.155	0.188	
				24.75		32.000	28.060	0.060	
				30.25					
				29.75					

All dimensions in mm

9 Standard Products

PART NO.	NOMINAL DIAMETER		WALL THICKNESS S_3 max. min.	WIDTH B max. min.	SHAFT Ø D_j [h8] max. min.	HOUSING Ø D_H [H7] max. min.	BUSH Ø $D_{i,a}$ ASSEMBLY IN H7 HOUSING max. min.	CLEARANCE C_D max. min.	OIL HOLE Ø d_L
	D_i	D_o							
PM3020HX	30	34	1.970 1.935	20.25	30.000 29.967	34.025 34.000	30.155 30.060	0.188 0.060	6
PM3025HX				19.75					
PM3030HX				25.25					
PM3040HX				24.75					
PM3220HX	32	36		20.25	32.000 31.961	36.025 36.000	32.155 32.060	0.194 0.060	
PM3230HX				19.75					
PM3235HX				30.25					
PM3240HX				29.75					
PM3520HX	35	39		20.25	35.000 34.961	39.025 39.000	35.155 35.060	0.194 0.060	
PM3530HX				19.75					
PM3535HX				30.25					
PM3540HX				29.75					
PM3550HX	36	40		35.25	36.000 35.961	40.025 40.000	36.155 36.060	0.194 0.060	
PM3635HX				34.75					
PM3720HX	37	41		20.25	37.000 36.961	41.025 41.000	37.155 37.060	0.234 0.080	
PM4020HX	40	44		19.75					
PM4030HX			20.25						
PM4040HX			30.25						
PM4050HX			29.75						
PM4520HX	45	50	20.25	45.000 44.961	50.025 50.000	45.195 45.080	0.234 0.080		
PM4525HX			19.75						
PM4530HX			25.25						
PM4540HX			24.75						
PM4545HX	50	55	30.25	50.000 49.961	55.030 55.000	50.200 50.080	0.239 0.080		
PM4550HX			29.75						
PM5030HX	50	55	40.25	50.000 49.961	55.030 55.000	50.200 50.080	0.239 0.080		
PM5040HX			39.75						
PM5045HX			45.25						
PM5050HX			44.75						
PM5060HX	50	55	50.25	50.000 49.961	55.030 55.000	50.200 50.080	0.239 0.080		
PM5060HX			49.75						

All dimensions in mm

PART NO.	NOMINAL DIAMETER		WALL THICKNESS S_3 max. min.	WIDTH B max. min.	SHAFT \emptyset D_j [h8] max. min.	HOUSING \emptyset D_H [H7] max. min.	BUSH \emptyset $D_{i,a}$ ASSEMBLY IN H7 HOUSING max. min.	CLEARANCE C_D max. min.	OIL HOLE $\emptyset d_L$
	D_i	D_o							
PM5520HX	55	60	2.460 2.415	20.25	55.000 54.954	60.030 60.000	55.200 55.080	0.246 0.080	8
PM5525HX				19.75					
PM5530HX				25.25					
PM5540HX				24.75					
PM5550HX				30.25					
PM5560HX				29.75					
PM6030HX	60	65	2.460 2.415	40.25	60.000 59.954	65.030 65.000	60.200 60.080	0.246 0.080	
PM6040HX				39.75					
PM6050HX				50.25					
PM6060HX				49.75					
PM6070HX				60.25					
PM6080HX				59.75					
PM6530HX	65	70	2.460 2.415	30.25	65.000 64.954	70.030 70.000	65.262 65.100	0.246 0.080	
PM6540HX				29.75					
PM6550HX				40.25					
PM6560HX				39.75					
PM6570HX				50.25					
PM6580HX				49.75					
PM7030HX	70	75	2.450 2.384	60.25	70.000 69.954	75.030 75.000	70.262 70.100	0.308 0.100	
PM7040HX				59.75					
PM7045HX				45.25					
PM7050HX				44.75					
PM7060HX				50.25					
PM7065HX				49.75					
PM7540HX	75	80	2.450 2.384	70.25	75.000 74.954	80.030 80.000	75.262 75.100	0.308 0.100	
PM7560HX				69.75					
PM7580HX				80.25					
PM8040HX	80	85	2.450 2.384	80.25	80.000 79.954	85.035 85.000	80.267 80.100	0.313 0.100	
PM8050HX				79.75					
PM8060HX				40.50					
PM8080HX				39.50					
PM80100HX				50.50					
	49.50								
	60.50								
	59.50								
	80.50								
	79.50								
	100.50								
	99.50								

All dimensions in mm

9 Standard Products

PART NO.	NOMINAL DIAMETER		WALL THICKNESS S_3 max. min.	WIDTH B max. min.	SHAFT Ø D_j [h8] max. min.	HOUSING Ø D_H [H7] max. min.	BUSH Ø $D_{i,a}$ ASSEMBLY IN H7 HOUSING max. min.	CLEARANCE C_D max. min.	OIL HOLE Ø d_L		
	D_i	D_o									
PM8530HX	85	90	2.450 2.384	30.50	85.000 84.946	90.035 90.000	85.267 85.100	0.321 0.100	9.5		
PM8540HX				29.50							
PM8560HX				40.50							
PM8580HX				39.50							
PM85100HX				60.50							
PM9040HX	59.50	90.000 89.946		40.50	95.035 95.000	90.267 90.100					
PM9060HX	39.50										
PM9080HX	60.50										
PM9090HX	59.50										
PM90100HX	80.50										
PM9560HX	79.50	95.000 94.946		60.50	100.035 100.000	95.267 95.100					
PM95100HX	59.50										
PM10040HX	100.50			100.000 99.946			40.50			105.035 105.000	100.267 100.100
PM10050HX	59.50										
PM10060HX	50.50										
PM10080HX	49.50										
PM10095HX	60.50										
PM100115HX	59.50	105.000 104.946	80.50	110.035 110.000	105.267 105.100						
PM10560HX	79.50										
PM10565HX	95.50										
PM105110HX	94.50										
PM105115HX	115.50										
PM11050HX	114.50	110.000 109.946	50.50	115.035 115.000	110.267 105.100						
PM11060HX	49.50										
PM110100HX	60.50										
PM110110HX	59.50										
PM110115HX	100.50										
PM11550HX	99.50	115.000 114.946	110.50	120.035 120.000	115.267 115.100						
PM11570HX	109.50										
PM12060HX	110.50										
PM120100HX	109.50										
PM120110HX	115.50										
PM12560HX	114.50	120.000 119.946	50.50	125.040 125.000	120.280 120.130						
PM125100HX	49.50										
PM125110HX	70.50										
PM125110HX	69.95										
PM125110HX	100.50										
PM125110HX	99.50	125.000 124.937	110.50	130.040 130.000	125.280 125.130						
PM125110HX	109.50										
PM125110HX	109.50										

PART NO.	NOMINAL DIAMETER		WALL THICKNESS S_3 max. min.	WIDTH B max. min.	SHAFT Ø D_j [h8] max. min.	HOUSING Ø D_H [H7] max. min.	BUSH Ø $D_{i,a}$ ASSEMBLY IN H7 HOUSING max. min.	CLEARANCE C_D max. min.	OIL HOLE Ø d_L				
	D_i	D_o											
PM13050HX	130	135	2.435 2.380	50.50	130.000	135.040	130.280	0.343 0.130	No hole				
PM13060HX				49.50						129.937	135.000		
PM13080HX				60.50								140.040	135.280
PM130100HX				59.50									
PM13560HX	80.50	145.040		140.280									
PM13580HX	79.50				145.000	140.130							
PM14050HX	100.50						155.040			150.280			
PM14060HX	99.50										155.000	150.130	
PM14080HX	60.50	165.040		160.280									
PM140100HX	59.50				165.000	160.130							
PM15050HX	80.50						175.040			170.280			
PM15060HX	79.50										175.000	170.130	
PM15080HX	100.50	185.046		180.286									
PM150100HX	99.50				185.000	180.130							
PM16050HX	50.50						195.046			190.286			
PM16060HX	49.50										195.000	190.130	
PM16080HX	60.50	205.046	200.286										
PM160100HX	59.50			205.000	200.130								
PM17050HX	80.50					200.000	200.000						
PM17060HX	79.50							205.046	200.286				
PM17080HX	100.50	205.000	200.130										
PM170100HX	99.50			205.000	200.130								
PM18050HX	50.50					190.000	195.046						
PM18060HX	49.50							195.000	190.286				
PM18080HX	60.50	199.928	199.928										
PM180100HX	59.50			199.928	199.928								
PM19050HX	80.50					190.000	195.046						
PM19060HX	79.50							195.000	190.286				
PM19080HX	100.50	205.046	200.286										
PM190100HX	99.50			205.000	200.130								
PM190120HX	120.50					200.000	200.000						
PM20050HX	119.50							205.046	200.286				
PM20060HX	50.50	205.000	200.130										
PM20080HX	49.50			205.000	200.130								
PM200100HX	60.50					205.000	200.130						
PM200120HX	59.50							205.000	200.130				
	80.50	205.000	200.130										
	79.50			205.000	200.130								
	100.50					205.000	200.130						
	99.50							205.000	200.130				
	120.50	205.000	200.130										
	119.50			205.000	200.130								

All dimensions in mm

9 Standard Products

PART NO.	NOMINAL DIAMETER		WALL THICKNESS S_3 max. min.	WIDTH B max. min.	SHAFT \emptyset D_j [h8] max. min.	HOUSING \emptyset D_H [H7] max. min.	BUSH \emptyset $D_{i,a}$ ASSEMBLY IN H7 HOUSING max. min.	CLEARANCE C_D max. min.	OIL HOLE $\emptyset d_L$
	D_i	D_o							
PM22050HX	220	225	2.435 2.380	50.50	220.000 219.928	225.046 225.000	220.286 220.130	0.358 0.130	No hole
PM22060HX				49.50					
PM22080HX				60.50					
PM220100HX				59.50					
PM220120HX				80.50					
PM24050HX	79.50								
PM24060HX	100.50								
PM24080HX	99.50								
PM240100HX	120.50								
PM240120HX	119.50								
PM25050HX	250	255		50.50	250.000 249.928	255.052 255.000	250.292 250.130	0.364 0.130	
PM25060HX				49.50					
PM25080HX				60.50					
PM250100HX				59.50					
PM250120HX				80.50					
PM26050HX	79.50								
PM26060HX	100.50								
PM26080HX	99.50								
PM260100HX	120.50								
PM260120HX	119.50								
PM28050HX	280	285	50.50	280.000 279.919	285.052 285.000	280.292 280.130	0.373 0.130		
PM28060HX			49.50						
PM28080HX			60.50						
PM280100HX			59.50						
PM280120HX			80.50						
PM30050HX	79.50								
PM30060HX	100.50								
PM30080HX	99.50								
PM300100HX	120.50								
PM300120HX	119.50								

All dimensions in mm

9.2 MB HI-EX® CYLINDRICAL BUSHES

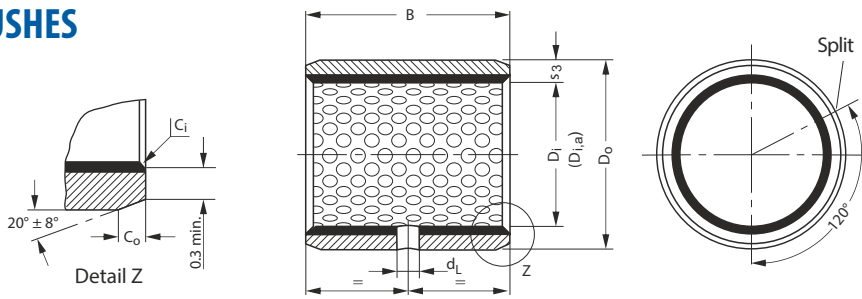

Dimensions and Tolerances according to ISO 3547 and GGB-Specifications

Note: For $D_i \leq 40$ mm, bush backing is tin flashed; for $D_i > 40$ mm, bush backing is copper flashed

OUTSIDE C_0 AND INSIDE C_i CHAMFERS

WALL THICKNESS S_3	C_0 (a)		C_i (b)
	MACHINED	ROLLED	
1	0.6 ± 0.4	0.6 ± 0.4	-0.1 to -0.5
1.5	0.6 ± 0.4	0.6 ± 0.4	-0.1 to -0.7

WALL THICKNESS S_3	C_0 (a)		C_i (b)
	MACHINED	ROLLED	
2	1.2 ± 0.4	1.0 ± 0.4	-0.1 to -0.7
2.5	1.8 ± 0.6	1.2 ± 0.4	-0.2 to -1.0

(a) = chamfer C_0 machined or rolled at the opinion of the manufacturer

(b) = C_i can be a radius or a chamfer in accordance with ISO 13715

PART NO.	NOMINAL DIAMETER		WALL THICKNESS S_3 max. min.	WIDTH B max. min.	SHAFT \emptyset D_{jm} [h8] max. min.	HOUSING \emptyset D_H [H7] max. min.	BUSH \emptyset $D_{i,a,m}$ ASSEMBLY IN H7 HOUSING max. min.	CLEARANCE C_{Dm} max. min.	OIL HOLE $\emptyset d_L$					
	D_i	D_o												
MB0808HX	8	10	1.108 1.082	8.25	7.960	10.015	8.015	0.077 0.040	No hole					
MB0810HX				7.75										
MB0812HX				10.25										
MB1010HX	9.75													
MB1012HX	12.25													
MB1015HX	11.75													
MB1020HX	10.25	9.960		12.018	10.018	0.080 0.040	3							
MB1210HX	9.75													
MB1212HX	12.25													
MB1215HX	11.75													
MB1220HX	15.25													
MB1225HX	14.75													
MB1415HX	12	14	1.108 1.082	20.25	d8	H7	14.018	12.018	0.095 0.050					
MB1420HX	19.75													
MB1425HX	25.25													
MB1510HX	24.75													
MB1512HX	10.25			13.950						16.018	14.018	17.018	15.018	3
MB1515HX	9.75													
MB1525HX	12.25													
	11.75													
	15.25													
	14.75													
	25.25	14.923		17.000	15.000	4								
	24.75													

All dimensions in mm

BESTELL NR.	NENNMAßE		WANDDICKE S ₃ max. min.	BREITE B max. min.	WELLEN-Ø D _J [h8] max. min.	GEHÄUSE-Ø D _H [H7] max. min.	BUCHSEN-Ø D _{1,a} EINGEBAUT IN H7 GEHÄUSE max. min.	LAGERSPIEL C _{Dm} max. min.	SCHMIER- LOCH-Ø d _L
	D _i	D _o							
MB1615HX	16	18	1.108 1.082	15.25	15.950 15.923	18.018 18.000	16.018 16.000	0.095 0.050	4
MB1620HX				20.25					
MB1625HX				25.25					
MB1815HX	18	20		15.25	17.950 17.923	20.021 20.000	18.018 18.000		
MB1820HX				20.25					
MB1825HX				25.25					
MB2010HX	20	23	1.608 1.576	10.25	19.935 19.902	23.021 23.000	20.021 20.000		
MB2015HX				15.25					
MB2020HX				20.25					
MB2025HX				25.25					
MB2030HX				30.25					
MB2215HX	22	25		15.25	21.935 21.902	25.021 25.000	22.021 22.000		
MB2220HX				20.25					
MB2225HX				25.25					
MB2230HX				30.25					
MB2415HX	24	27		15.25	23.935 23.902	27.021 27.000	24.021 24.000		
MB2420HX				20.25					
MB2425HX				25.25					
MB2430HX			30.25						
MB2515HX	25	28	15.25	24.935 24.902	28.021 28.000	25.021 25.000			
MB2520HX			20.25						
MB2525HX			25.25						
MB2530HX			30.25						
MB2820HX	28	32	20.25	27.935 27.902	32.025 32.000	28.021 28.000			
MB2825HX			25.25						
MB2830HX			30.25						
MB3020HX	30	34	20.25	30.000 29.967	34.025 34.000	30.021 30.000			
MB3030HX			30.25						
MB3040HX			40.25						
MB3220HX	32	36	20.25	31.920 31.881	36.025 36.000	32.025 32.000			
MB3230HX			19.75						
MB3235HX			35.25						
MB3240HX			37.75						
MB3520HX	35	39	20.25	34.920 34.881	39.025 39.000	35.025 35.000			
MB3530HX			19.75						
MB3550HX			50.25						
MB3720HX	37	41	49.75	36.920	41.025	37.025	0.144 0.080		
			19.75	36.881	41.000	37.000			

All dimensions in mm

BESTELL NR.	NENNMASSE		WANDDICKE S ₃ max. min.	BREITE B max. min.	WELLEN-Ø D _J [h8] max. min.	GEHÄUSE-Ø D _H [H7] max. min.	BUCHSEN-Ø D _{i,a} EINGEBAUT IN H7 GEHÄUSE max. min.	LAGERSPIEL C _{Dm} max. min.	SCHMIER- LOCH-Ø d _L
	D _i	D _o							
MB4020HX	40	44	2.108 2.072	20.25	39.920 39.881	44.025 44.000	40.025 40.000	0.144 0.080	8
MB4030HX				19.75					
MB4040HX				30.25					
MB4050HX				29.75					
MB4520HX	45	50	2.634 2.588	20.25	44.920 44.881	50.025 50.000	45.025 45.000	0.144 0.080	8
MB4530HX				19.75					
MB4540HX				30.25					
MB4545HX				29.75					
MB4550HX				40.25					
MB5040HX				39.75					
MB5060HX	60.25								
MB5520HX	55	60	2.634 2.588	20.25	54.900 54.854	60.030 60.000	55.030 55.000	0.176 0.100	8
MB5525HX				19.75					
MB5530HX				25.25					
MB5540HX				24.75					
MB5550HX				30.25					
MB5560HX				29.75					
MB6030HX	60	65	2.634 2.588	40.25	59.900 59.854	65.030 65.000	60.030 60.000	0.176 0.100	8
MB6040HX				19.75					
MB6060HX				25.25					
MB6070HX				24.75					
MB6540HX	65	70	2.634 2.588	40.25	64.900 64.854	70.030 70.000	65.030 65.000	0.176 0.100	8
MB6550HX				19.75					
MB6560HX				30.25					
MB6570HX				29.75					
MB7040HX	70	75	2.634 2.588	40.25	69.900 69.854	75.030 75.000	70.030 70.000	0.176 0.100	8
MB7050HX				19.75					
MB7065HX				30.25					
MB7070HX				29.75					
MB7080HX				40.25					
MB7540HX				39.75					
MB7560HX	60.25								
MB7580HX	59.75								
MB8040HX	80	85	2.634 2.588	40.50	79.900 79.854	85.035 85.000	80.030 80.000	0.176 0.100	9.5
MB8060HX				39.50					
MB8080HX				60.50					
MB80100HX				59.50					

All dimensions in mm

BESTELL NR.	NENNMÄßE		WANDDICKE S ₃ max. min.	BREITE B max. min.	WELLEN-Ø D _J [h8] max. min.	GEHÄUSE-Ø D _H [H7] max. min.	BUCHSEN-Ø D _{i,a} EINGEBAUT IN H7 GEHÄUSE max. min.	LAGERSPIEL C _{Dm} max. min.	SCHMIER- LOCH-Ø d _L
	D _i	D _o							
MB8530HX	85	90	2.634 2.568	30.50	84.880 84.826	90.035 90.000	85.035 85.000	0.209 0.120	9.5
MB8540HX				29.50					
MB8560HX				40.50					
MB8580HX				39.50					
MB85100HX				60.50					
MB9040HX	90	95		80.50	89.880 89.826	95.035 95.000	90.035 90.000		
MB9060HX				79.50					
MB9090HX				100.50					
MB90100HX				99.50					
MB9560HX				40.50					
MB95100HX	95	100		39.50	94.880 94.826	100.035 100.000	95.035 95.000		
MB10050HX				60.50					
MB10060HX				59.50					
MB10080HX				100.50					
MB10095HX				99.50					
MB100115HX	100	105		50.50	99.880 99.826	105.035 105.000	100.035 100.000		
MB10560HX				49.50					
MB105110HX				60.50					
MB105115HX				59.50					
MB11060HX				80.50					
MB110115HX	110	115	79.50	104.880 104.826	110.035 110.000	105.035 105.000			
MB11550HX			95.50						
MB11570HX			94.50						
MB12060HX			115.50						
MB120100HX			114.50						
MB125100HX	120	125	60.50	109.880 109.826	115.035 115.000	110.035 110.000			
MB13050HX			59.50						
MB13060HX			110.50						
MB130100HX			109.50						
MB13560HX			115.50						
MB13580HX	130	135	114.50	114.880 114.826	120.035 120.000	115.035 115.000			
MB14060HX			70.50						
MB140100HX			69.50						
MB15060HX			119.880						
MB15080HX			119.826						
MB150100HX	135	140	60.50	124.855 124.792	125.040 125.000	125.040 125.000			
MB13560HX			59.50						
MB13580HX			100.50						
MB14060HX			99.50						
MB140100HX			124.855						
MB15060HX	140	145	50.50	129.855 129.792	130.040 130.000	135.040 135.000			
MB15080HX			49.50						
MB150100HX			60.50						
MB15060HX			59.50						
MB15080HX			134.855						
MB150100HX	150	155	80.50	139.855 139.792	140.040 140.000	135.040 135.000			
MB15060HX			79.50						
MB15080HX			100.50						
MB150100HX			99.50						
MB15060HX			60.50						
MB15080HX	150	155	59.50	149.855 149.792	145.040 145.000	140.040 140.000			
MB150100HX			80.50						
MB15060HX			79.50						
MB15080HX			100.50						
MB150100HX			99.50						

All dimensions in mm

9 Standard Products

9.3 HI-EX® THRUST WASHERS

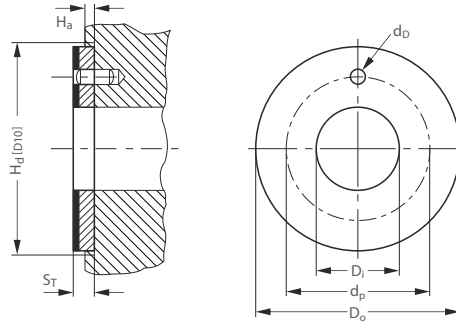

PART NO.	INSIDE DIAMETER		THICKNESS S_T max. min.	DOWEL HOLE		RECESS DEPTH H_a max. min.
	D_i max. min.	D_o max. min.		$\emptyset d_D$ max. min.	PCD $\emptyset d_p$ max. min.	
WC08HX	10.25 10.00	20.00 19.75	1.58 1.49	-	-	1.20 0.95
WC10HX	12.25	24.00		1.875	18.12	
	12.00	23.75		1.625	17.88	
WC12HX	14.25	26.00		2.375	20.12	
	14.00	25.75			19.88	
WC14HX	16.25	30.00		2.125	22.12	
	16.00	29.75			21.88	
WC16HX	18.25	32.00		3.375	25.12	
	18.00	31.75			24.88	
WC18HX	20.25	36.00		3.125	28.12	
	20.00	35.75			27.88	
WC20HX	22.25	38.00		4.375	30.12	
	22.00	37.75			29.88	
WC22HX	24.25	42.00		4.125	33.12	
	24.00	41.75	32.88			
WC24HX	26.25	44.00	4.375	35.12		
	26.00	43.75		34.88		
WC25HX	28.25	48.00	4.125	38.12		
	28.00	47.75		37.88		
WC30HX	32.25	54.00	2.60	43.12		
	32.00	53.75		42.88		
WC35HX	38.25	62.00	2.51	50.12		
	38.00	61.75		49.88		
WC40HX	42.25	66.00	1.70	54.12		
	42.00	65.75		53.88		
WC45HX	48.25	74.00	1.45	61.12		
	48.00	73.75		60.88		
WC50HX	52.25	78.00		65.12		
	52.00	77.75		64.88		
WC60HX	62.25	90.00		76.12		
	62.00	89.75		75.88		

All dimensions in mm

9.4 HI-EX® SLIDING PLATES

HI-EX® Sliding Plate sizes are available as Non-Standard products, on request.

10 Test Methods

10.1 MEASUREMENT OF WRAPPED BUSHES

It is not possible to accurately measure the external and internal diameters of a wrapped bush in the free condition. In its free state a wrapped bush will not be perfectly cylindrical and the butt joint may be open. When correctly installed in a housing the butt joint will be tightly closed and the bush will conform to the housing. For this reason the external diameter and internal diameter of a wrapped bush can only be checked with special gauges and test equipment.

The checking methods are defined in ISO 3547 Parts 1 to 7.

TEST A OF ISO 3547 PART 2

Checking the external diameter in a test machine with checking blocks and adjusting mandrel.

TEST A OF ISO 3547 PART 2 ON PM2015HX	
Checking block and setting mandrel $d_{ch,1}$	23.062 mm
Test force F_{ch}	4500 N
Limits for Δz	0 and -0.065 mm
Bush Outside diameter D_o	23.035 to 23.075 mm

Table 7 : Test A of ISO 3547 Part 2

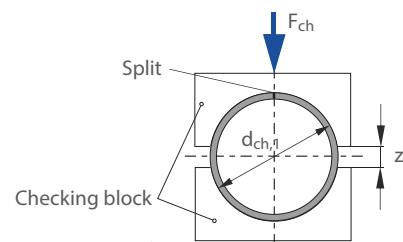

Fig.34 : Test A, data for drawing

TEST B (ALTERNATIVELY TO TEST A)

Check external diameter with GO and NOGO ring gauges.

TEST C

Checking the internal diameter of a bush pressed into a ring gauge, which nominal diameter corresponds to the dimension specified in table 6 of ISO 3547 Part 2 (Example $D_i = 20$ mm).

MEASUREMENT OF WALL THICKNESS (ALTERNATIVELY TO TEST C)

The wall thickness is measured at one, two or three positions axially according to the bearing dimensions.

TEST D

Check external diameter by precision measuring tape.

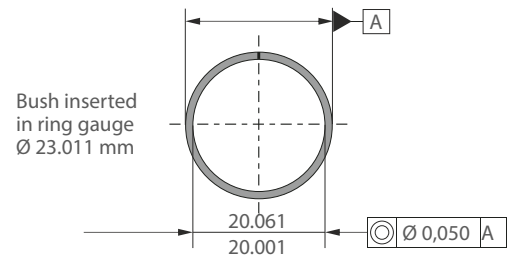

Fig.35 : Test C, data for drawing

Bearing Application Data Sheet



Please complete the form below and share it with your sales engineer.

DATA FOR BEARING DESIGN CALCULATION

Application: _____

Project/No.: _____ Quantity: _____ New design Existing design

Steady load Rotating load Rotational movement Oscillating movement Linear movement

DIMENSIONS [mm]

Inside diameter	D_i	
Outside diameter	D_o	
Length	B	
Flange diameter	D_{fl}	
Flange thickness	B_{fl}	
Wall thickness	S_T	
Length of slideplate	L	
Width of slideplate	W	
Thickness of slideplate	S_s	

LOAD

- Static load
 Dynamic load

Axial load F	[N]	
Radial load F	[N]	

MOVEMENT

Rotational speed	N [1/min]	
Speed	U [m/s]	
Length of stroke	L_s [mm]	
Frequency of stroke	[1/min]	

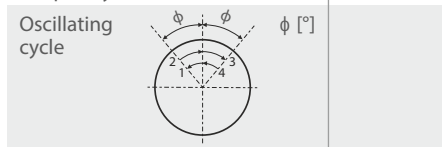

Osc. frequency	N_{osz} [1/min]	
----------------	-------------------	--

MATING SURFACE

Material		
Hardness	HB/HRC	
Surface finish	Ra [μ m]	

CUSTOMER INFORMATION

Company _____

Street _____

City / State / Province / Post Code _____

Telephone _____ Fax _____

Name _____

Email Address _____ Date _____

FITS & TOLERANCES

Shaft	D_j	
Bearing housing	D_H	

OPERATING ENVIRONMENT

Ambient temperature	T_{amb} [°]	
Bearing housing material		

- Housing with good heating transfer properties
 Light pressing or insulated housing with poor heat transfer properties
 Non metal housing with poor heat transfer properties
 Alternate operation in water and dry

LUBRICATION

- Dry
 Continuous lubrication
 Process fluid lubrication
 Initial lubrication only
 Hydrodynamic conditions

Process fluid		
Lubricant		
Dynamic viscosity	η [mPas]	

SERVICE HOURS PER DAY

Continuous operation		
Intermittent operation		
Operating time		
Days per year		

SERVICE LIFE

Required service life	L_H [h]	
-----------------------	-----------	--

BEARING TYPE

- Cylindrical bush

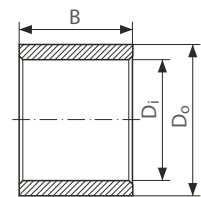

- Flanged bush

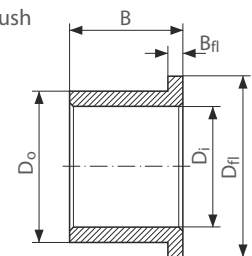

- Thrust washer

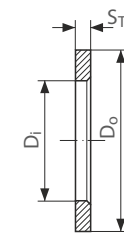

- Slideplate

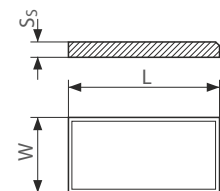

- Special parts (sketch)

Formula Symbols And Designations

SYMBOL	UNIT	DESIGNATION
a_B	-	Bearing size factor
a_E	-	High load factor
a_Q	-	Speed / load factor
a_S	-	Surface finish factor
a_T	-	Temperature application factor
B	mm	Nominal bush length
C	1/min	Dynamic load frequency
C_D	mm	Installed diametrical clearance
C_{Dm}	mm	Diametral clearance machined
C_i	mm	ID chamfer length
C_o	mm	OD chamfer length
C_T	-	Total number of dynamic load cycles
D_H	mm	Housing Diameter
D_i	mm	Nominal bush and thrust washer ID
$D_{i,a}$	mm	Bush ID when assembled in housing
$D_{i,a,m}$	mm	Bush ID assembled and machined
D_J	mm	Shaft diameter
D_{Jm}	mm	Shaft diameter for machined bushes
D_o	mm	Nominal bush and thrust washer OD
d_D	mm	Dowel hole diameter
d_L	mm	Oil hole diameter
d_p	mm	Pitch circle diameter for dowel hole
F	N	Bearing load
F_i	N	Insertion force
f	-	Friction
H_a	mm	Depth of housing recess (e.g. for thrust washers)
H_d	mm	Diameter of housing recess (e.g. for thrust washers)
L	mm	Strip length
L_H	h	Bearing service life
L_{RG}	h	Relubrication interval

SYMBOL	UNIT	DESIGNATION
N	1/min	Rotational speed
N_{osc}	1/min	Oscillating movement frequency
P	N/mm ²	Specific load
P_{lim}	N/mm ²	Specific load limit
$P_{sta,max}$	N/mm ²	Maximum static load
$P_{dyn,max}$	N/mm ²	Maximum dynamic load
Q	-	Total number of cycles
R	-	Number of lubrication intervals
R_a	μm	Surface roughness (DIN 4768, ISO/DIN 4287/1)
s_3	mm	Bush wall thickness
s_5	mm	Strip thickness
s_T	mm	Thrust washer thickness
T	°C	Temperature
T_{amb}	°C	Ambient temperature
T_{max}	°C	Maximum temperature
T_{min}	°C	Minimum temperature
U	m/s	Sliding speed
u	-	Speed factor
W	mm	Strip width
$W_{u,min}$	mm	Minimum usable strip width
Z_T	-	Total number of cycles
α_1	1/10 ⁶ K	Coefficient of linear thermal expansion parallel to surface
α_2	1/10 ⁶ K	Coefficient of linear thermal expansion normal to surface
σ_c	N/mm ²	Compressive yield strength
λ	W/mK	Thermal conductivity
φ	°	Angular displacement
η	Ns/mm ²	Dynamic viscosity

Product Information

This document is provided to give you the analysis tools or information to assist you in product selection. Product performance is affected by many factors beyond the control of GGB. Therefore, you must validate the suitability and feasibility of all product selections for your applications.

GGB products are sold subject to GGB's Terms of Sale and Delivery, which include our limited warranty and remedy. You can find these here: <https://www.ggbearings.com/en/terms-and-conditions>, or ask your GGB representative for a copy.

Products are subject to continual development. GGB retains the right to make specification amendments or improvements to the technical data without prior announcement.

DOCUMENT INFORMATION

Edition 2024. This edition replaces earlier editions which hereby lose their validity.

Every reasonable effort has been made to ensure the accuracy of the information in this writing, but GGB assumes no liability for errors or omissions or for any other reason.

HEALTH AND SAFETY

GGB is committed to adhering to all U.S., European and international standards and regulations with regard to lead content. We have established internal processes that monitor any changes to existing standards and regulations, and we work collaboratively with customers and distributors to ensure that all requirements are followed. This includes RoHS and REACH guidelines.

GGB is committed to operating in an environmentally conscious and safe manner. We follow numerous industry best practices and are committed to meeting or exceeding a variety of internationally recognized standards for emissions control and workplace safety.

Each of our global locations has management systems in place that adhere to IATF 16949, ISO 9001, ISO 14001 and ISO 45001 quality regulations. Our certificates can be found here:

<https://www.ggbearings.com/en/company/certificates>.

A detailed explanation of our commitment to REACH and RoHS directives can be found at

<https://www.ggbearings.com/en/reach-rohs>.



Stronger. Together.



GGB NORTH AMERICA

P.O. Box 189 | 700 Mid Atlantic Parkway

USA | Thorofare, New Jersey, 08086

Tel: +1 856 848 3200

www.ggbearings.com

HB109ENG10-24USA